

# Keysight W4640A and W4630A Series DDR4 BGA Interposers for Logic Analyzers

Data Sheet

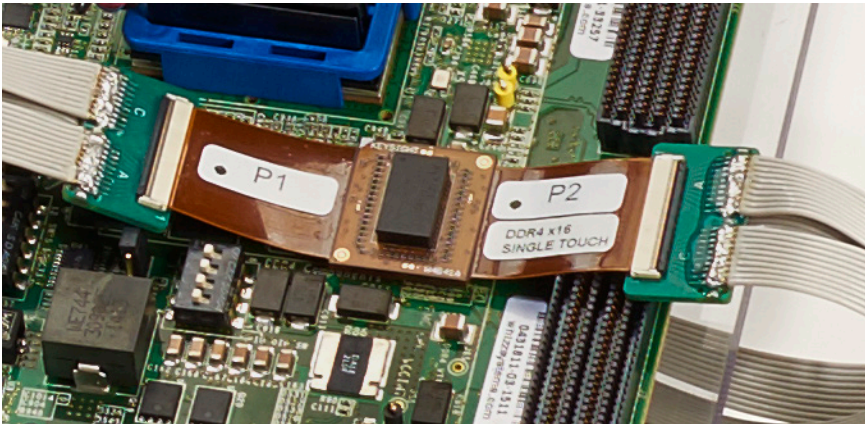

# Table of Contents

Overview .....	03
The DDR4 BGA Interposer Advantage .....	03
W4640A Series DDR4 BGA Interposer Selection Guide .....	04
W4630A Series DDR4 BGA Interposer Selection Guide .....	04
W4640 Series DDR4 BGA Interposers and 61-pin ZIF Probe/Cables	
W4643A: DDR4 x4/x8 BGA Interposer 2-wing, 3.2 Gb/s .....	05
– Technical Characteristics .....	05
– Dimensional Drawings.....	09
W4641A: DDR4 x16 BGA Interposer 2-wing, 3.2 Gb/s.....	11
– Technical Characteristics .....	11
– Dimensional Drawings.....	16
U4208A: Left Wing, Probe/Cable, 61-pin ZIF.....	17
– Technical Characteristics .....	17
U4209A: Right Wing, Probe/Cable, 61-pin ZIF .....	18
– Technical Characteristics .....	18
W4633A DDR4, x4/x8, 3-wing BGA Interposer.....	19
– Technical Characteristics .....	19
– Dimensional Drawings.....	23
W4631A DDR4 x16, 4-wing BGA Interposer.....	26
– Technical Characteristics .....	26
– Dimensional Drawings.....	31
W4636A DDR4 x16, 2-wing BGA Interposer.....	33
– Technical Characteristics .....	33
– Dimensional Drawings.....	37
DDR EyeFinder and EyeScan Software .....	38
Optional Software .....	39
DDR4 BGA Interposer and Cabling Selection Guide.....	41
Logic Analyzer Configuration Guide and Ordering Information.....	42
– Related Products.....	43
– Related Literature.....	43

## Overview

The W4640A and The W4630A series DDR4 BGA interposers enable probing of embedded memory DRAM from the ball grid array with Keysight Technologies, Inc. logic analyzers.

The Keysight W4630A series DDR4 BGA interposers for logic analyzers enable viewing of data traffic on industry standard DDR4 DRAMs with the Keysight U4164A and U4154A/B logic analysis systems.

The W4640A Series DDR4 BGA interposers are designed to take full advantage of quad sample state mode on U4164A modules with Option 02G, requiring only a single probe point for up to four samples at two different thresholds. The W4640A Series DDR4 BGA interposers have the industry's smallest KOV (keep out volume) for interposers capable of capturing over 2400 Mb/s data rate DDR4 traffic. W4640A Series BGA interposers are designed to capture data rates in excess of 3.2 Gb/s.

## The DDR4 BGA Interposer Advantage

Features	Benefits
Connects directly to the DDR4 BGA balls.	Eliminates reflections from mid-bus probing methods. Also eliminates design time, prototype builds, and trace routing required to design in alternative probing methods.
Supports: <ul style="list-style-type: none"> <li>– DDR4 78 ball single die, stacked, or quad x4, x8 DRAM at data rates up to and including 3.2 Gb/s with W4633A or W4643A</li> <li>– DDR4 96 ball single die x16 DRAM with at data rates up to and including 3.2 Gb/s with W4631A or W4641A</li> <li>– Enables DDR eyescan display of DDR4 signals into logic analyzer module from BGA interposer</li> <li>– Enables DDR4, decode, functional compliance and performance analysis using optional software tools</li> <li>– Using APS (Advanced Probe Settings <sup>1</sup> to enable DQ (data) capture over 1866 Mb/s</li> </ul>	Get complete signal access to the DDR4 signals critical to your debug.
Supports either leaded or lead-free solder.	Easily works with all solder finishes. Designed to tolerate lead-free soldering temperature profiles.
Contract manufactures available for those without the in-house expertise or facilities for soldering BGAs.	Eliminates the need to develop BGA soldering expertise.
Flexible “wings” with ZIF connectors.	Ensures reliable connection to the ZIF probes. Enables placement of the probe cables around adjacent components. Minimizes the torque to the balls of the BGA.

1. To enable Advanced Probe Settings refer to Tech brief # 5991-0799EN. Maximum transfer rates are subject to variables in the signal integrity of the system under test.

## W4640A Series DDR4 BGA Interposer Selection Guide

Memory family	DRAM type	Package	Data rates	Signal coverage	Use model	Keysight BGA interposer
DDR4	X4	78-ball BGA, JEDEC MO-207M footprint variation DT-z, with a maximum DRAM package size of 11 x 14 mm	In excess of 3.2 Gb/s	<ul style="list-style-type: none"> <li>– Address (ADD): All</li> <li>– (DQ/DQS): All</li> <li>– (CMD)/control: All with the exception of VREFCA, TEN, ZQ</li> </ul>	Maximum signal access at highest data rates with smallest KOV and lowest probe load	W4643A 2- wing
DDR4	X8	78-ball BGA, JEDEC MO-207M footprint variation DT-z, with a maximum DRAM package size of 11 x 14 mm	In excess of 3.2 Gb/s	<ul style="list-style-type: none"> <li>– Address (ADD): All</li> <li>– (DQ/DQS): All</li> <li>– (CMD)/control: All with the exception of VREFCA, TEN, ZQ</li> </ul>	Maximum signal access at highest data rates with smallest KOV and lowest probe load	W4643A 2- wing
DDR4	X16	96-ball BGA, JEDEC MO-207M footprint variation DU-z, with a maximum size of 12.5 mm x 19 mm	In excess of 3.2 Gb/s	<ul style="list-style-type: none"> <li>– Address (ADD): All data</li> <li>– (DQ/DQS): All with the exception of DQSL_c</li> <li>– (CMD)/control: All with the exception of VREFCA, TEN, ZQ</li> </ul>	Maximum signal access at highest data rates with smallest KOV and lowest probe load	W4641A 2-wing

1. Maximum DRAM package that can fit on top of the DDR4 BGA interposer without an additional riser, optional grypper, or socket (not provided) to provide clearance for the RC components.

## W4630A Series DDR4 BGA Interposer Selection Guide

Memory family	DRAM type	Package	Data rates	Signal coverage	Use model	Keysight BGA interposer
DDR4	x4 single channel	78-ball BGA, JEDEC MO-207M footprint variation DT-z, with a maximum DRAM package size of 11 x 14 mm <sup>1</sup>	In excess of 3.2 Gb/s	<ul style="list-style-type: none"> <li>– Address (ADD): All</li> <li>– (DQ/DQS): All</li> <li>– (CMD)/Control: All with the exception of VREFCA, TEN, ZQ</li> </ul>	Maximum signal access at highest data rates	W4633A 3-wing
DDR4	x8	78-ball BGA, JEDEC MO-207M footprint variation DT-z, with a maximum DRAM package size of 11 x 14 mm <sup>1</sup>	In excess of 3.2 Gb/s	<ul style="list-style-type: none"> <li>– Address (ADD): All</li> <li>– (DQ/DQS): All</li> <li>– (CMD)/Control: All with the exception of VREFCA, TEN, ZQ</li> </ul>	Maximum signal access at highest data rates	W4633A 3-wing
DDR4	x16	96-ball BGA, JEDEC MO-207M footprint variation DU-z, with a maximum size of 12.5 mm x 19 mm <sup>1</sup>	In excess of 3.2 Gb/s	<ul style="list-style-type: none"> <li>– Address (ADD): All</li> <li>– (DQ/DQS): All</li> <li>– (CMD)/Control: All with the exception of VREFCA, TEN, ZQ</li> </ul>	Maximum signal access at highest data rates	W4631A 4-wing
DDR4	x16	96-ball BGA, JEDEC MO-207M footprint variation DU-z, with a maximum size of 12.5 mm x 19 mm <sup>1</sup>	≤ 2.4 Gb/s	<ul style="list-style-type: none"> <li>– Address (ADD): All</li> <li>– (DQ/DQS): All with the exception of... DQL1, DQL2, DQL3, DQL4, DQL5, DQL6, DQL7, DQSLt, DQSLc, DQSUt</li> <li>– Command (CMD)/Control: All with the exception of VREFCA, TEN, ZQ</li> </ul>	Designed for minimal KOV for space limited systems under test. Provides access for functional validation at lowest probing cost	W4636A 2-wing

1. Maximum DRAM package that can fit on top of the DDR4 BGA interposer without an additional riser, optional grypper, or socket (not provided) to provide clearance for the RC components.

# W4640 Series DDR4 BGA Interposers and 61-pin ZIF Probe/Cables

## W4643A: DDR4 x4/x8 BGA Interposer 2-wing, 3.2 Gb/s

### Technical Characteristics

#### Description

Keysight Technologies W4643A DDR4, x4/x8, 2-wing BGA interposers are proven to capture DDR4 ADD/CMD/DQ/DQS at data rates in excess of 3.2 Gb/s. The W4643A is a rigid/flex BGA interposer that enables probing of chip down DDR4 DRAM (x4 or x8) directly at the ball grid array using Keysight logic analyzers.

#### W4643A DDR4 x4/x8, 2-wing, 3.2 Gb/s, BGA interposer features

DDR4 device support	DDR4 single-channel x4/x8 DRAM BGA chip
DDR4 data rate support	In excess of 3.2 Gb/s
BGA package footprint support	78-ball, JEDEC MO-207M footprint variation DT-z
BGA package size support	Maximum of 12 mm x 13.5 mm DDR4 DRAM package can fit on top of the W4643A interposer without an additional riser or optional grypper or other socket to provide clearance for the RC components
Signal-to-signal timing skew	Timing skews are within $\pm 25$ ps
Signal isolation	RC (resistor/capacitor) isolation networks for proper logic analyzer probing are installed on the top of the W4643A
Connectors	2 zero-insertion force (ZIF) connectors
Form factor	Rigid/flex 2-wing BGA interposer
Logic analyzer compatibility	U4164A with option -02G for quad state mode operation

#### W4643A includes

- DDR4 78-ball, x4/x8, 2-wing BGA interposer
- 78-ball riser for devices under test that have components surrounding the DDR4 x4/x8 DRAM to be probed when the surrounding components are too close to install the W4643A without the riser. The riser includes a ground plane. Riser orientation is critical for proper operation

#### W4643A requires

- One U4208A 61-pin ZIF probe/cable to connect between the left wing of the W4643A BGA interposer and compatible logic analyzer
- One U4209A 61-pin ZIF, probe/cable to connect between the right wing of the W4643A BGA interposer and compatible logic analyzer
- One U4164A logic analyzer module in a chassis with host controller

#### Optional for the W4643A

- One DDR4 78 ball riser (included) for devices under test that have components surrounding the DDR4 x4/x8 DRAM to be probed, where the surrounding components are too close to install the W4643A without the riser
- The DDR4 78-ball riser may be replaced with an optional grypper socket that is sold separately: <http://www.hsiotech.com/products/released-products/engineering-products/grypper-family>

# W4640 Series DDR4 BGA Interposers and 61-pin ZIF Probe/Cables

## W4643A: DDR4 x4/x8 BGA Interposer 2-wing, 3.2 Gb/s (Continued)

### Signals probed

The BGA interposer solutions provide access to the DDR4 signals highlighted below and pass all power and ground signals between the system and memory chip.

	1	2	3	4	5	6	7	8	9	
A	VDD	GND	TDQS_c				DBL_n	GND	GND	A
B	VPP	VDDQ	DQS_c				DQ1	VDDQ	ZQ	B
C	VDDQ	DQ0	DQS_t				VDD	GND	VDDQ	C
D	GND	DQ4	DQ2				DQ3	DQ5	GND	D
E	GND	VDDQ	DQ6				DQ7	VDDQ	GND	E
F	VDD	C2	ODT				CK_t	CK_c	VDDQ	F
G	GND	C0	CKE				CS_n	C1	TEN	G
H	GND	A14	ACT_n				A15	A16	GND	H
J	VrefCA	BG0	A10				A12	BG1	VDDQ	J
K	GND	BA0	A4				A3	BA1	GND	K
L	RST_n	A6	A0				A1	A5	ALERT_N	L
M	VDD	A8	A2				A9	A7	VPP	M
N	GND	A11	PAR				A17	A13	VDDQ	N



	Quad-sample input	Pod 1 CK = CK_t/CK_c
	Single-sample input	Pod 3 CK = CKE
	Clock/Qualifier input	Pod 5 CK = NC
		Pod 7 CK = RESET_N

Figure 1. W4643A signals probed.

### Signal access

All signals, including power and ground signals, are passed between the system and memory chip. The W4643A includes a VDDQ plane on the top layer. There are four capacitor footprints to allow the user to add power filter capacitors on VDDQ if the system under test requires additional power filtering.

The following signals are omitted from the logic analyzer connection for the W4643 x4/x8 BGA interposer systems:

- Address signal group
  - None
- Control and other signals group
  - VREFCA, - TEN, ZQ
- Data signal group
  - None

DDR4 device power is not monitored by the logic analyzer. Power is passed through the interposer through vias. The interposer includes multiple ground planes. Interposers are delivered with RC (resistor/capacitor) networks for logic analyzer probing installed on top of each W4643A.

For additional installation information, refer to the W4640A and W4630A Series installation guide at <http://literature.cdn.keysight.com/litweb/pdf/W4631-97000.pdf>.

# W4640 Series DDR4 BGA Interposers and 61-pin ZIF Probe/Cables

## W4643A: DDR4 x4/x8 BGA Interposer 2-wing, 3.2 Gb/s (Continued)

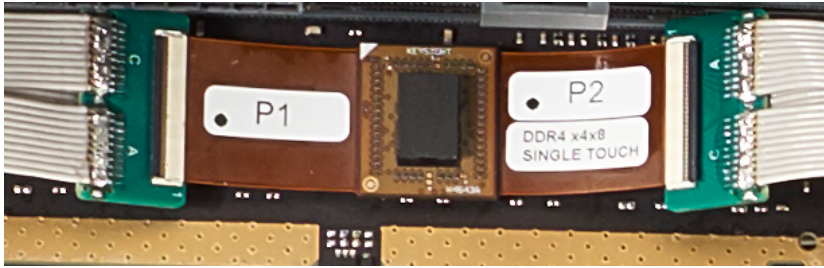

Figure 2. W4643A x4/x8, 2-wing BGA interposer with U4208A and U4209A 61-pin ZIF probe/cables attached.

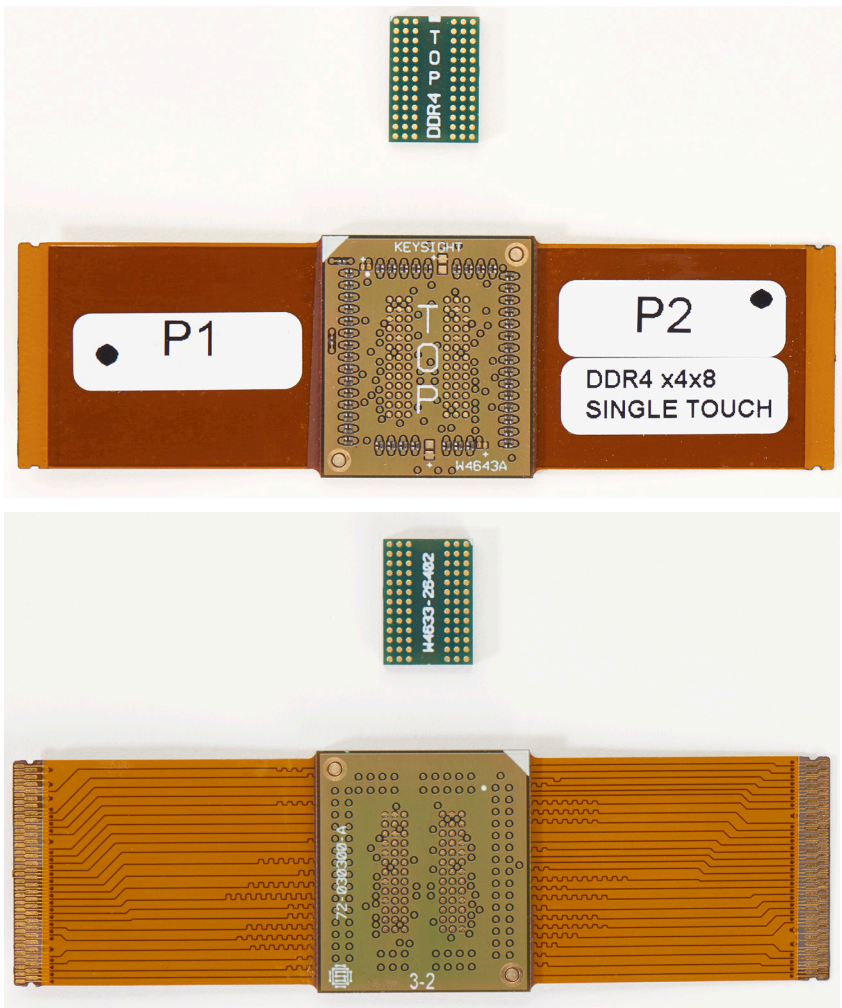

Figure 3a and 3b. W4643A DDR4 x4/x8, BGA interposer 78-ball riser top and bottom views.

# W4640 Series DDR4 BGA Interposers and 61-pin ZIF Probe/Cables

## W4643A: DDR4 x4/x8 BGA Interposer 2-wing, 3.2 Gb/s (Continued)

### W4643A connections to logic analyzer

#### DDR4 x4/x8 Logic Analyzer Interposer

Logic analyzer pod					
BIT	B	D	A	C	BIT
0	A0	DQ6	A9	DQ5	0
1	PAR		A17		1
2	A2	DQ4	A1	DQ7	2
3	A11		A13		3
4			A7	DQ3	4
5	A8		A5		5
6	A6	DQ0	A3	DQ1	6
7	BA0		A15		7
8	A4	DQS_t	BA1	DBI_n	8
9	BG0		BG1		9
10	A10	DQS_c	A12		10
11	A14		A16		11
12	C0	DQ2	ALERT_n		12
13	ACT_n		C1		13
14	C2	TDQ_c	CS_n		14
15	ODT				15
CLK	CKE	RST_n	CK_t		CLK
CLK#	GND	GND	CK_c		CLK#
	U4208A		U4209A		
Logic Analyzer Pods	Pod 3	Pod 7	Pod 1	Pod 5	
	Dual	Quad	Dual	Quad	

 Clock inputs are highlighted in yellow

### W4643A connections for all data rates with one U4208A and one U4209A 61-pin ZIF probe/cable and default software configurations <sup>1</sup>

Reference designator	Logic analyzer pods
U4209A Pod A	Pod 1
U4208A Pod B	Pod 3
U4209A Pod C	Pod 5
U4208A Pod D	Pod 7

1. Default configurations are provided in the standard (no-cost) features of the B4661A memory analysis software.

### Configuration considerations

- May require riser or optional (not included) grypper socket between system under test and BGA interposer. Depends on KOV available on device under test.
- Requires APS (Advanced Probe Settings) enabled on logic analyzer to enable highest data rate captures.



# W4640 Series DDR4 BGA Interposers and 61-pin ZIF Probe/Cables W4643A: DDR4 x4/x8 BGA Interposer 2-wing, 3.2 Gb/s (Continued)

## Dimensional Drawings

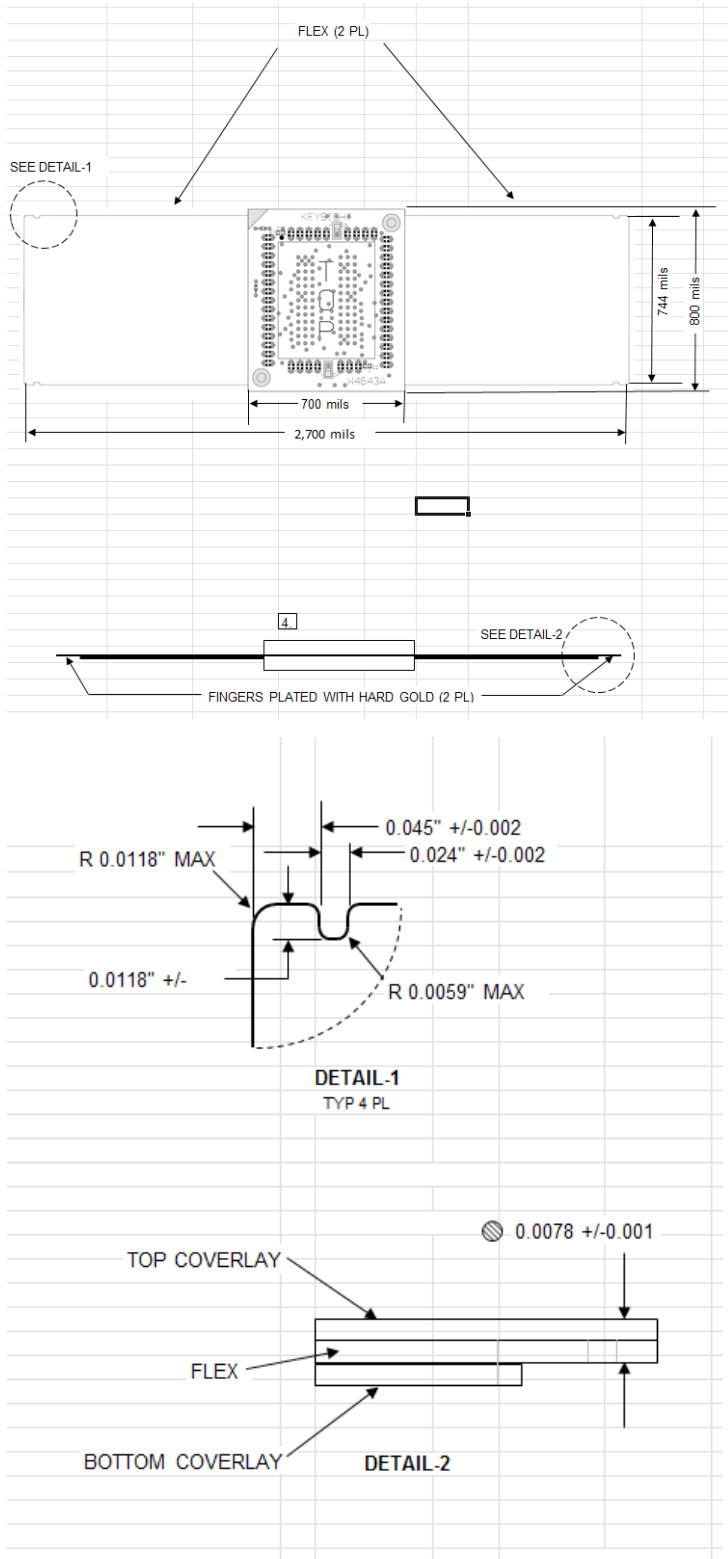
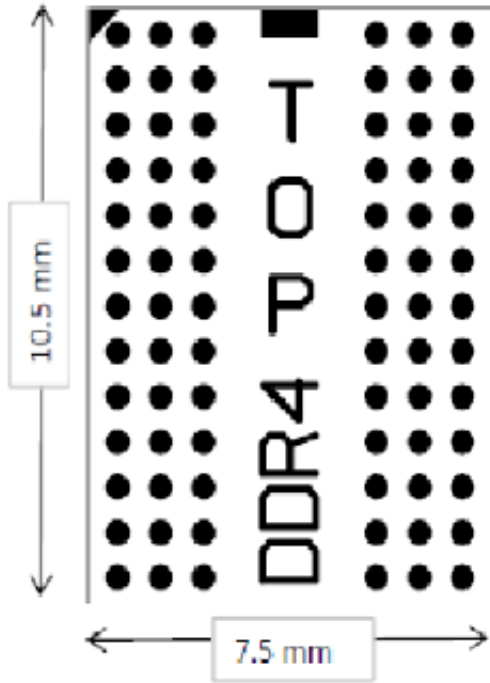

Figure 4. W4643A dimensions top view and side views

# W4640 Series DDR4 BGA Interposers and 61-pin ZIF Probe/Cables

## W4643A: DDR4 x4/x8 BGA Interposer 2-wing, 3.2 Gb/s (Continued)

### Dimensional Drawings (Continued)



0.0501 Minimum allowable thickness  
(corresponds to 1.5 mm)

Figure 5. DDR4 x4/x8 riser dimensions. (Dimensions provided are nominal and may vary by  $\pm 0.25$  mm.)

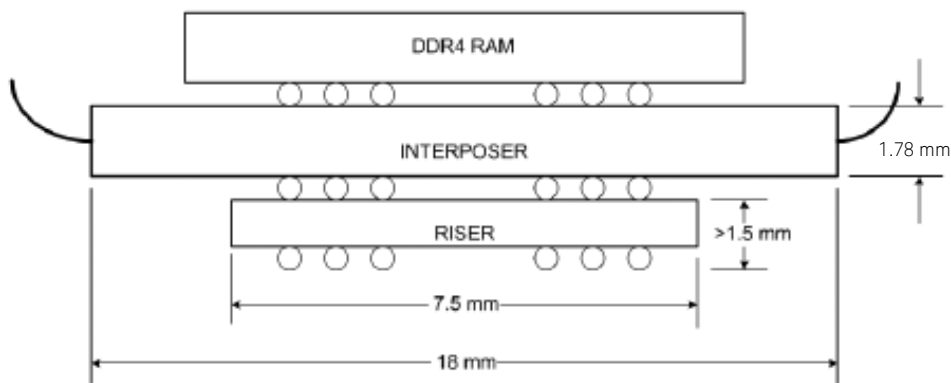

Figure 6. Dimensional diagram of W4643A x4/x8 interposer/RAM stack-up with riser.

# W4641A: DDR4 x16 BGA Interposer 2-wing, 3.2 Gb/s

## Technical Characteristics

### Description

The Keysight Technologies W4641A DDR4, x16, 2-wing BGA interposers are designed to capture DDR4 ADD/CMD/DQ/DQS at data rates in excess of 3.2 Gb/s. The W4641A is a rigid/flex BGA interposer that enables probing of chip down DDR4 DRAM (x16) directly at the ball grid array using Keysight logic analyzers.

<b>W4641A DDR4 x16, 2-wing, 3.2 Gb/s, BGA interposer features</b>	
DDR4 device support	DDR4 single-channel x16 DRAM BGA chip
DDR4 data rate support	In excess of 3.2 Gb/s
BGA package footprint support	96-ball, JEDEC MO-207M footprint variation DU-z
BGA package size support	Maximum of 12 mm x 15 mm DDR4 DRAM package can fit on top of the W4641A interposer without an additional riser or optional grypper or other socket to provide clearance for the RC components
Signal-to-signal timing skew	Timing skews are within $\pm 25$ ps
Signal isolation	RC (resistor/capacitor) isolation networks for proper logic analyzer probing are installed on the top of the W4641A
Connectors	2 zero-insertion force (ZIF) connectors
Form factor	Rigid/flex 2-wing BGA interposer
Logic analyzer compatibility	U4164A with option -02G for quad state mode operation

W4641A includes

- DDR4 96-ball, x16, 2-wing BGA interposer
- 96-ball riser for devices under test that have components surrounding the DDR4 x16 DRAM to be probed when the surrounding components are too close to install the W4643A without the riser. The riser includes a ground plane. Riser orientation is critical for proper operation

W4641A requires

- One U4208A 61-pin ZIF probe/cable to connect between the left wing of the W4641A BGA interposer and compatible logic analyzer
- One U4209A 61-pin ZIF, probe/cable to connect between the right wing of the W4641A BGA interposer and compatible logic analyzer
- One U4164A logic analyzer module in a chassis with host controller

Optional for the W4641A

- One DDR4 96-ball riser (included) for devices under test that have components surrounding the DDR4 x16 DRAM to be probed, where the surrounding components are too close to install the W4643A without the riser.
- The DDR4 96-ball riser may be replaced with an optional grypper socket that is sold separately: <http://www.hsiotech.com/products/released-products/engineering-products/grypper-family>.

## W4641A: DDR4 x16 BGA Interposer 2-wing, 3.2 Gb/s (Continued)

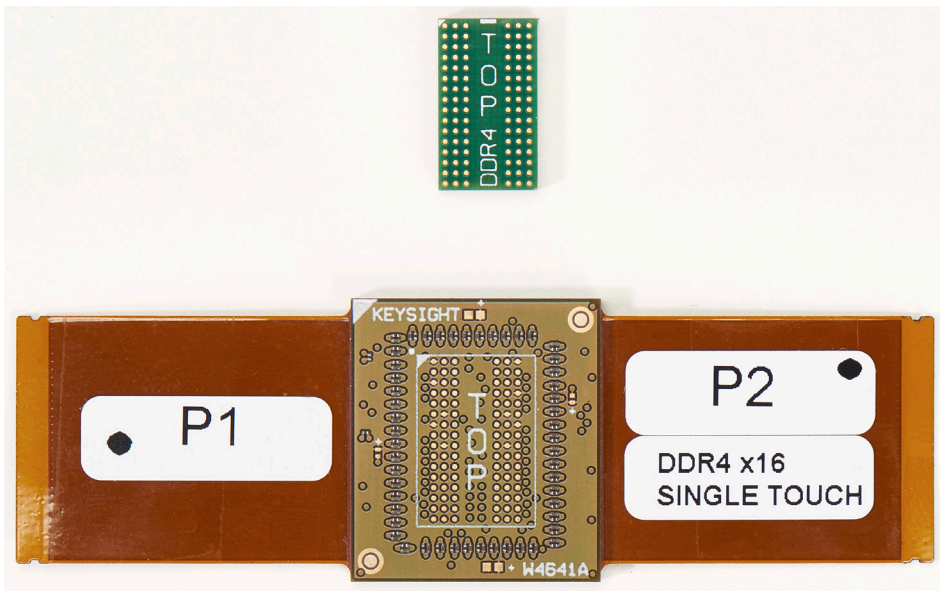
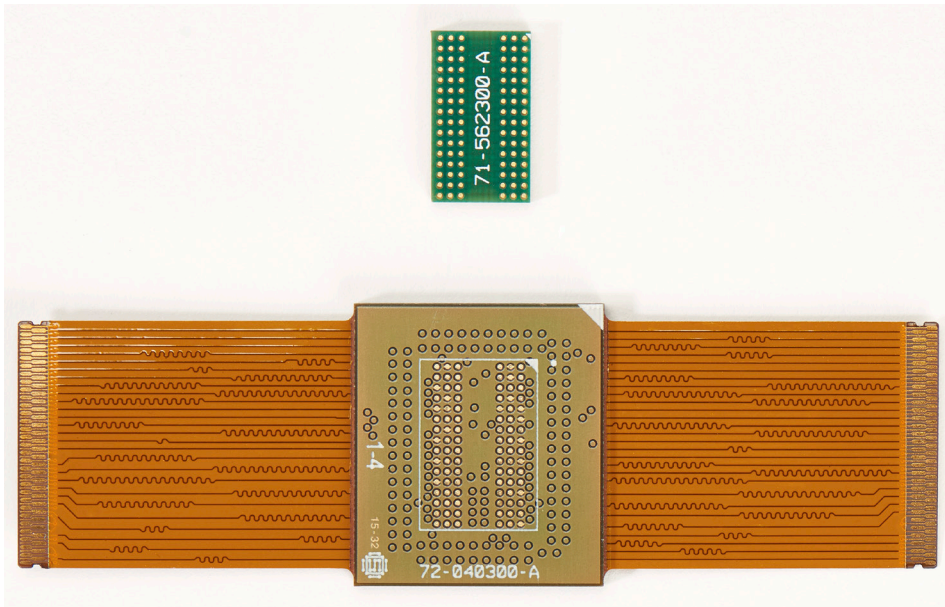

Figures 7a and 7b. W4641A with 96-ball riser, top and bottom views.

# W4641A: DDR4 x16 BGA Interposer 2-wing, 3.2 Gb/s (Continued)

## Signals probed

The BGA interposer solutions provide access to the DDR4 signals highlighted below and pass all power and ground signals between the system and memory chip.

	1	2	3	4	5	6	7	8	9	
A	VDDQ	GND	DQU0				DQSU_c	GND	VDDQ	A
B	VPP	GND	VDD				DQSU_t	DQU1	VDD	B
C	VDDQ	DQU4	DQU2				DQU3	DQU5	GND	C
D	VDD	GND	DQU6				DQU7	GND	VDDQ	D
E	GND	DMU_n	GND				DML_n	GND	GND	E
F	GND	VDDQ	DQSL_c				DQL1	VDDQ	ZQ	F
G	VDDQ	DQL0	DQSL_t				VDD	GND	VDDQ	G
H	GND	DQL4	DQL2				DQL3	DQL5	GND	H
J	VDD	VDDQ	DQL6				DQL7	VDDQ	VDD	J
K	GND	CKE	ODT				CK_t	CK_c	GND	K
L	VDD	A14	ACT_n				CS_n	A16	VDD	L
M	VREFCA	BG0	A10				A12	A15	GND	M
N	GND	BA0	A4				A3	BA1	TEN	N
P	RST_n	A6	A0				A1	A5	ALERT_n	P
R	VDD	A8	A2				A9	A7	VPP	R
T	GND	A11	PAR				NC	A13	VDD	T

	Quad-sample input
	Dual-sample input
	Clock/Qualifier input
	Double probed input
	Single probed, dual sample input

Pod 1 CK = CK\_t/CK\_c  
 Pod 3 CK = CKE  
 Pod 5 CK = DQSU\_t/DQSU\_c  
 Pod 7 CK = RST\_N

Figure 8. W4641A signals probed.

## W4641A: DDR4 x16 BGA Interposer 2-wing, 3.2 Gb/s (Continued)

### Signal access

All signals, including power and ground signals, are passed between the system and memory chip.

The following signals are omitted from the logic analyzer connection for the W4641A x16 BGA interposer systems:

- Address signal group
  - None
- Control and other signals group
  - VREFCA, - TEN, ZQ
- Data signal group
  - DQSL\_c

DDR4 device power is not monitored by the logic analyzer. Power is passed through the interposer through vias. The interposer includes multiple ground planes and a VDDQ plane on the top layer. There are four capacitor footprints to allow the user to add power filter capacitors on VDDQ for systems that require additional power filtering. Interposers are delivered with RC (resistor/capacitor) networks for logic analyzer probing installed on top of each W4641A.

For additional installation information, refer to the W4640A and W4630A Series installation guide at <http://literature.cdn.keysight.com/litweb/pdf/W4631-97000.pdf>.

## W4641A: DDR4 x16 BGA Interposer 2-wing, 3.2 Gb/s (Continued)

### DDR4 x4/x8 Logic Analyzer Interposer

Logic analyzer pod					
BIT	B	D	A	C	BIT
0	A4	DQL6	A3	DQL7	0
1	A2				1
2	A0	DQL2	A9	DQL5	2
3	A10		A1		3
4	PAR	DQL4	A12	DQL3	4
5	A11		A13		5
6	A8	DQU4	A7	DQU7	6
7	A6		A5		7
8	BA0	DQU6	ALERT_n	DQU5	8
9	BG0		BA1		9
10	ACT_n	DQU0	A15	DQU3	10
11	ODT				11
12	A14	DQU2	A16	DQU1	12
13	DQSL_t		CS_n		13
14	DMU_n	DQL0	DML_n	DQL1	14
15	DMU_n		DML_n		15
CLK	CKE	RST_n	CK_t	DQSU_t	CLK
CLK#	GND	GND	CK_c	DQSU_c	CLK#
	U4208A		U4209A		
Logic Analyzer Pods	Pod 3	Pod 7	Pod 1	Pod 5	
	Dual	Quad	Dual	Quad	

	Clock/Qualifier input
	Quad-sample data input

Clock/Qualifier on Pod 1 (CK\_t/CK\_c) and Pod 5 (DQSU\_t/DQSU\_c) are also available in Quad-sample mode.

Figure 9. W4641A signal mapping to logic analyzer pods.

### W4641A connections for all data rates with one U4208A and one U4209A 61-pin ZIF probe/cable and default software configurations <sup>1</sup>

Reference designator	Logic analyzer pods
U4209A Pod A	Pod 1
U4208A Pod B	Pod 3
U4209A Pod C	Pod 5
U4208A Pod D	Pod 7

1. Default configurations are provided in the standard (no-cost) features of the B4661A memory analysis software

### Configuration considerations

- May require riser or optional (not included) gryppler socket between system under test and BGA interposer. Depends on KOV available on device under test.
- Requires APS (Advanced Probe Settings) enabled on logic analyzer to enable highest data rate captures.

# W4641A: DDR4 x16 BGA Interposer 2-wing, 3.2 Gb/s (Continued)

## Dimensional Drawings

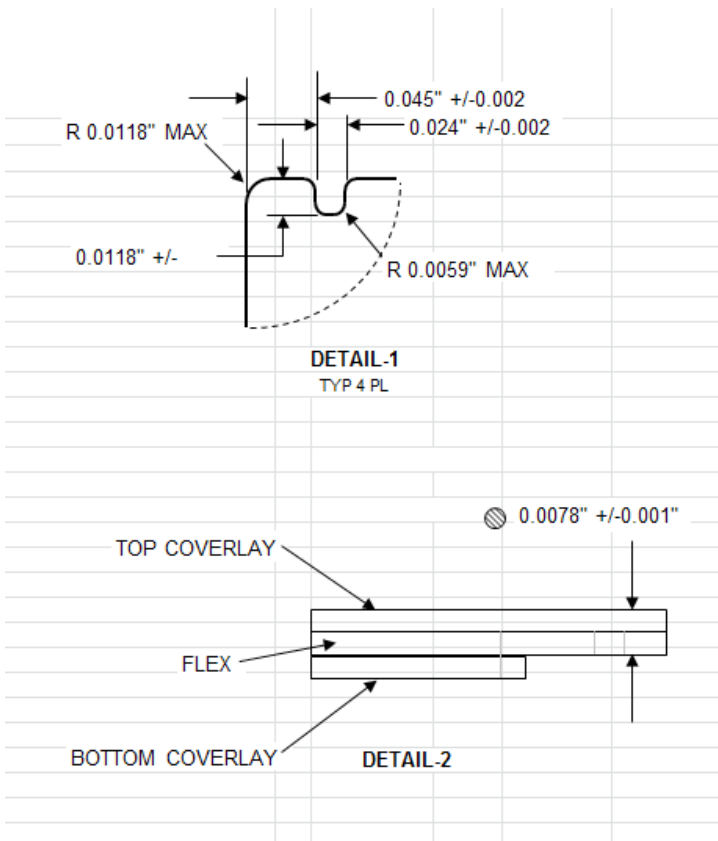
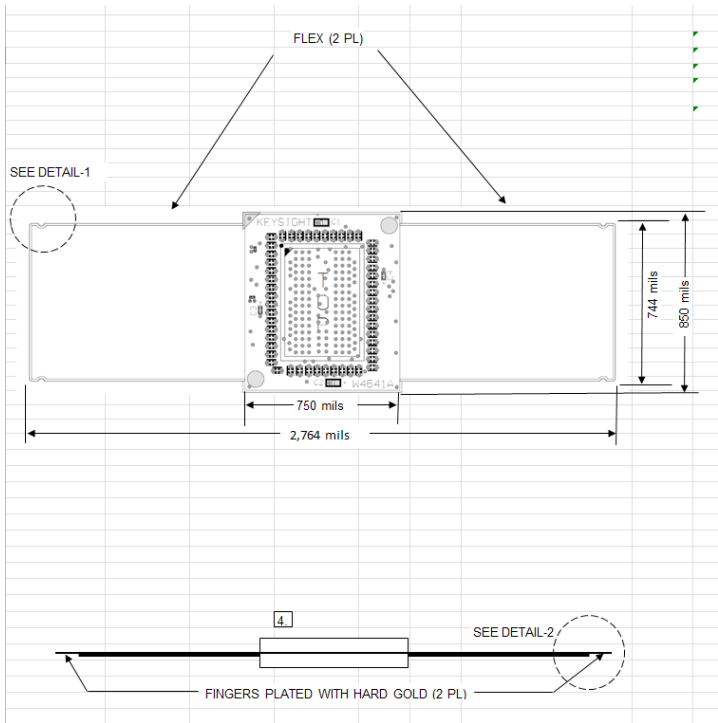

Figure 10. W4641A dimensions top and side views.



# U4208A: Left Wing, Probe/Cable, 61-pin ZIF

## Technical Characteristics

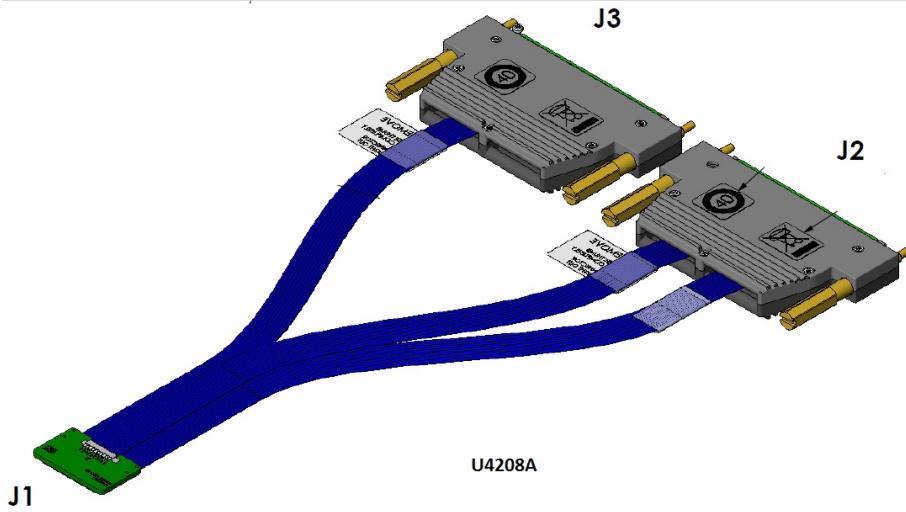

Figure 11. U4208A.

The U4208A ships with:

- U4208A probe/cable, 61-pin ZIF, from left wing, no RC, 160-pin direct connect to logic analyzer front panel connector (qty 1)
- ESD bag (qty 1)

### Compatible logic analyzer modules

U4164A with option -02G in quad sample state mode.

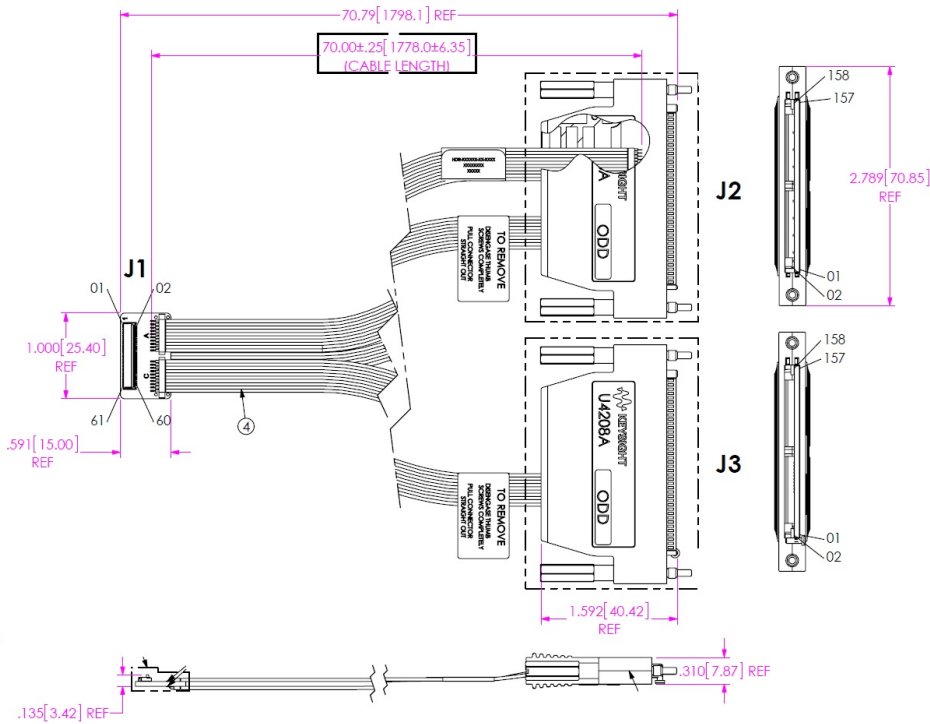

Figure 12. U4208A dimensional drawing.

# U4209A: Right Wing, Probe/Cable, 61-pin ZIF

## Technical Characteristics

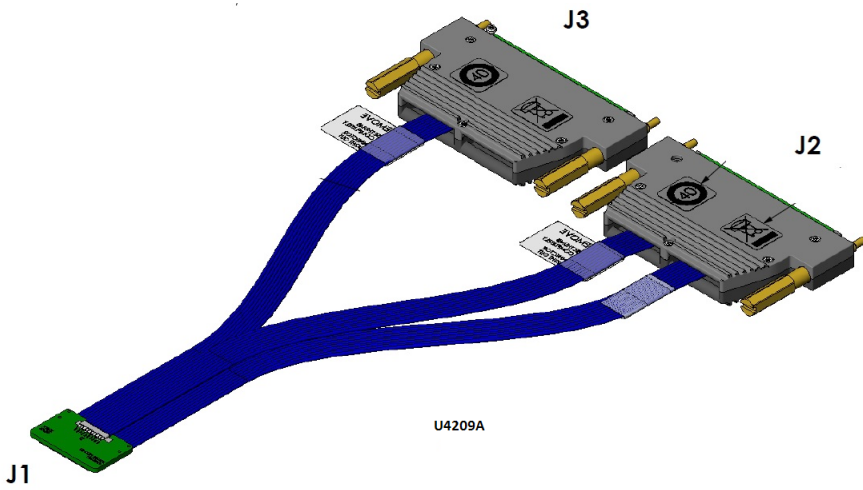

Figure 13. U4209A.

The U4209A ships with:

- U4209A probe/cable, 61-pin ZIF, from right wing, no RC, 160-pin direct connect to logic analyzer front panel connector (qty 1)
- ESD bag (qty 1)

### Compatible logic analyzer modules

U4164A with option -02G in quad sample state mode.

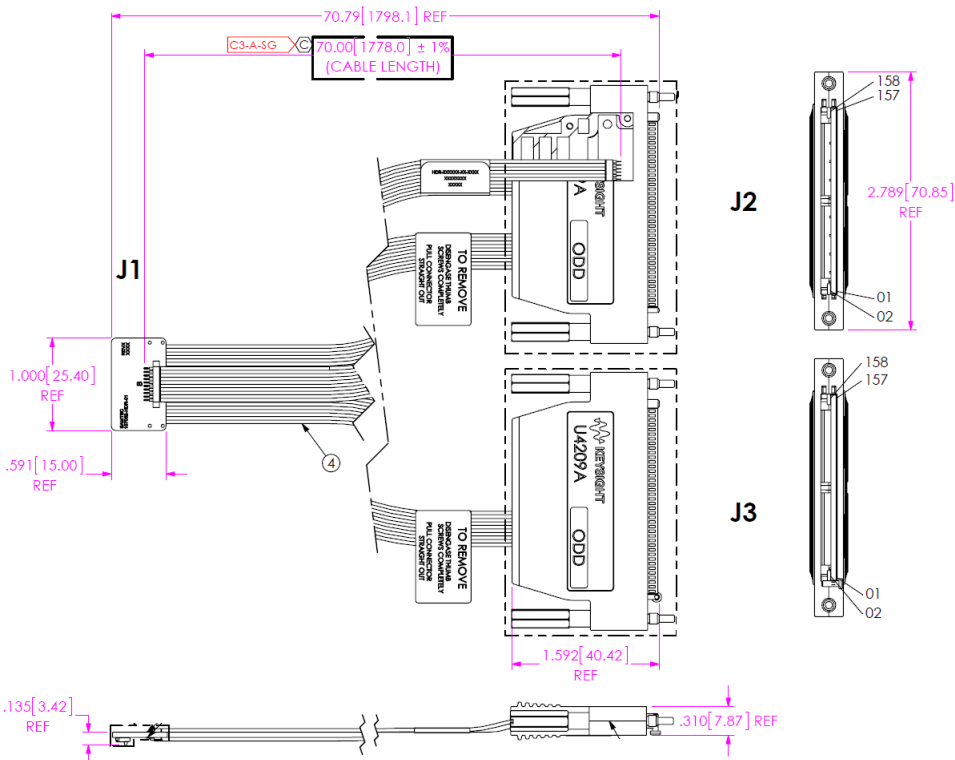

Figure 14. U4209A dimensions.

# W4633A DDR4, x4/x8, 3-wing BGA Interposer

## Technical Characteristics

### Description

The Keysight Technologies W4633A DDR4, x4/x8, 3-wing BGA interposers is proven to capture DDR4 ADD/CMD/DQ/DQS at 3.2 Gb/s. The W4633A is a rigid/flex BGA interposer that enables probing of chip down DDR4 DRAM (x4 or x8) directly at the ball grid array using Keysight logic analyzers.

<b>W4633A DDR4 BGA interposer features</b>	
DDR4 device support	DDR4 single-channel x4 or x8 DRAM BGA chip
DDR4 data rate support	In excess of 3.2 Gb/s
BGA package footprint support	78-ball, JEDEC MO-207M footprint variation DT-z
BGA package size support	Maximum of 11 mm x 14 mm DDR4 DRAM package can fit on top of the W4633A interposer without an additional riser or optional grypper or other socket to provide clearance for the RC components
Signal-to-signal timing skew	Timing skews are within $\pm 25$ ps
Signal isolation	RC (resistor/capacitor) isolation networks for proper logic analyzer probing are installed on the top and bottom of the W4633A
Connectors	Three zero-insertion force (ZIF) connectors
Form factor	Rigid/flex 3-wing BGA interposer
Logic analyzer compatibility	U4154A/B

W4633A includes

- DDR4 78-ball, x4/x8, 3-wing BGA interposer
- 78-ball riser. The riser is required to provide clearance for the interposer's bottom RC networks and surrounding devices. The riser includes a ground plane. Riser orientation is critical for proper operation

W4633A requires

- Two E5849A ZIF cables to connect between W4633A BGA interposer and compatible logic analyzer
- One compatible logic analyzer module in a chassis with host controller

Optional for the W4633A

- The DDR4 78-ball riser may be replaced with an optional grypper socket which is sold separately: <http://www.hsiotech.com/products/released-products/engineering-products/grypper-family>

## W4633A DDR4, x4/x8, 3-wing BGA Interposer (Continued)

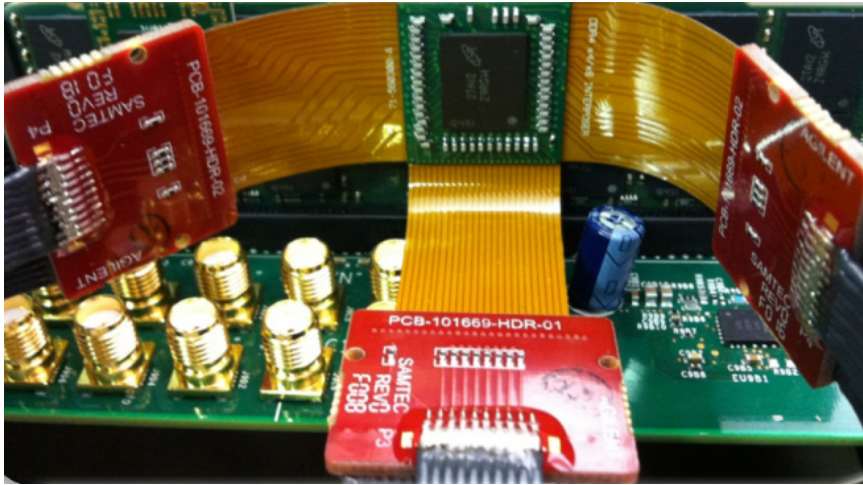

Figure 15a and 15b. W4633A x4/x8, 3-wing BGA interposer with two E5849A DDR4 ZIF probes attached. Note that the ZIF door closes on the bottom side of the wings. This is true for both the W4633A and W4631A DDR4 BGA interposers.

## W4633A DDR4, x4/x8, 3-wing BGA Interposer (Continued)

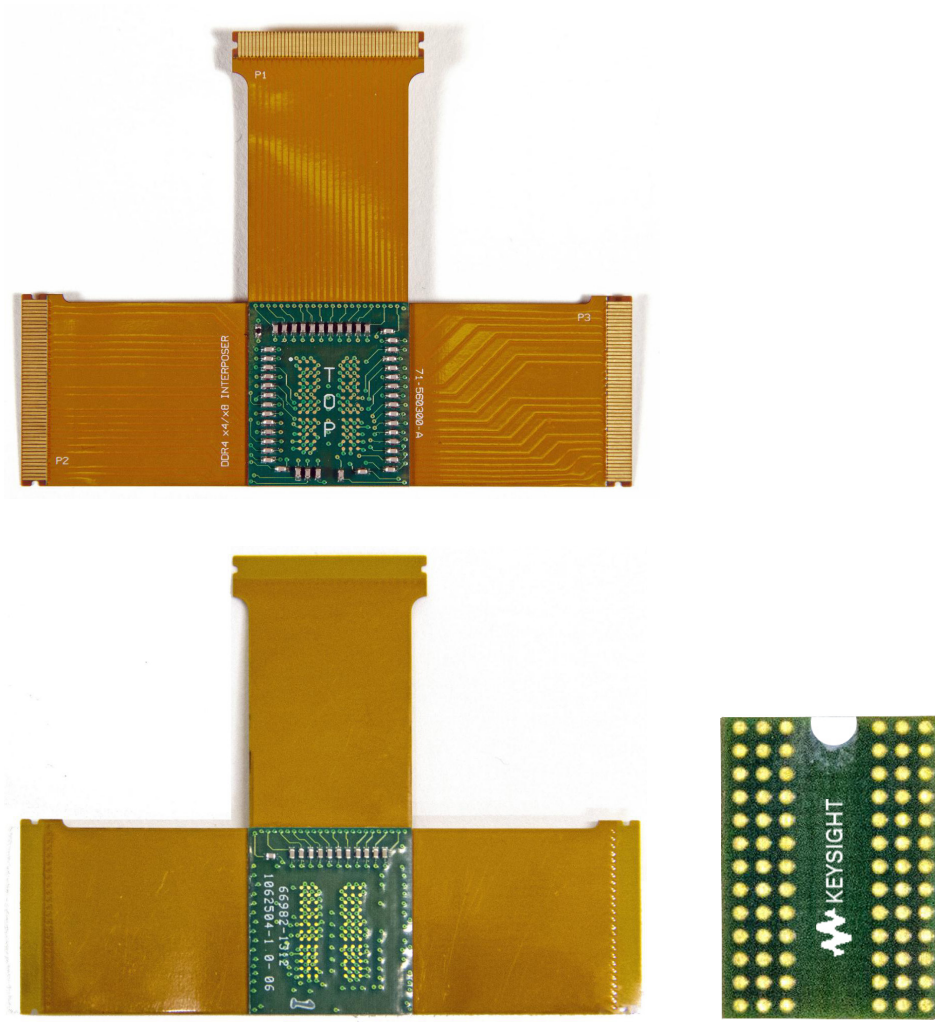

Figure 16. W4633A top and bottom views and DDR4 x4/x8, 78-ball riser.

# W4633A DDR4, x4/x8, 3-wing BGA Interposer (Continued)

## Signals probed

The BGA interposer solutions provide access to the DDR4 signals highlighted below and pass all power and ground signals between the system and memory chip.

**DDR4**

	1	2	3	4	5	6	7	8	9	
A	VDD	GND	TDQS_c				DM_n/DBI/ TDQS_t	GND	GND	A
B	VPP	VDDQ	DQS_c				DQ1	VDDQ	ZQ	B
C	VDDQ	DQ0	DQS_t				VDD	GND	VDDQ	C
D	GND	DQ4	DQ2				DQ3	DQ5	GND	D
E	GND	VDDQ	DQ6				DQ7	VDDQ	GND	E
F	VDD	C2/ ODT1	ODT				CK_t	CK_c	VDDQ	F
G	GND	C0/ CKE1	CKE				CS_n	C1/ CS1_n	TEN	G
H	VDD	WE_n/ A14	ACT_n				CAS_n/ A15	RAS-n/ A16	GND	H
J	VrefCA	BG0	A10/ AP				A12 BC_n	BG1	VDDQ	J
K	GND	BA0	A4				A3	BA1	GND	K
L	RESET_n	A6	A0				A1	A5	ALERT_n/ VMON	L
M	VDD	A8	A2				A9	A7	VPP	M
N	GND	A11	PARITY				A17/ NC	A13	VDDQ	N
	1	2	3	4	5	6	7	8	9	

# of signals (probed)			
P1	12	CLOCKS	(Clock input on Logic Analyzer)
P2	17	POWER	Not probed
P3	17 (15 plus a differential clock)	OTHER	Not probed

Figure 17. W4633A DDR4 x4/x8 BGA interposer signals probed; Top view.

## Signal access

All signals, including power and ground signals, are passed between the system and memory chip.

DDR4 signal group	Logic analyzer signal access
Address	All
Control and other signals	All except VREFCA, TEN, ZQ
Data	All
Power	DDR4 device power is not monitored by the logic analyzer. Power is passed through the interposer through vias
Ground	Interposer includes multiple ground planes

For additional installation information, refer to the W4630A Series installation guide at <http://literature.cdn.keysight.com/litweb/pdf/W4631-97000.pdf>.

## W4633A DDR4, x4/x8, 3-wing BGA Interposer (Continued)

### W4633A connections to logic analyzer

W4633A connections using two E5849A ZIF probes and default software configurations for less than or equal to 2.5 Gb/s and for more than 2.5 Gb/s data rates.

Reference designator	Logic analyzer pods
E5849A Probe 2 Pod A	Pod 1
E5849A Probe 2 Pod C	Pod 2
E5849A Probe 1 Pod C	Pod 3
E5849A Probe 1 Pod B	Pod 5
E5849A Probe 1 Pod A	Pod 7

### Configuration considerations

- Requires riser or optional (not included) grypper socket between system under test and BGA interposer.
- Requires APS (Advanced Probe Settings) enabled on logic analyzer to enable highest data rate captures over 1866 Mb/s.

### Dimensional drawings

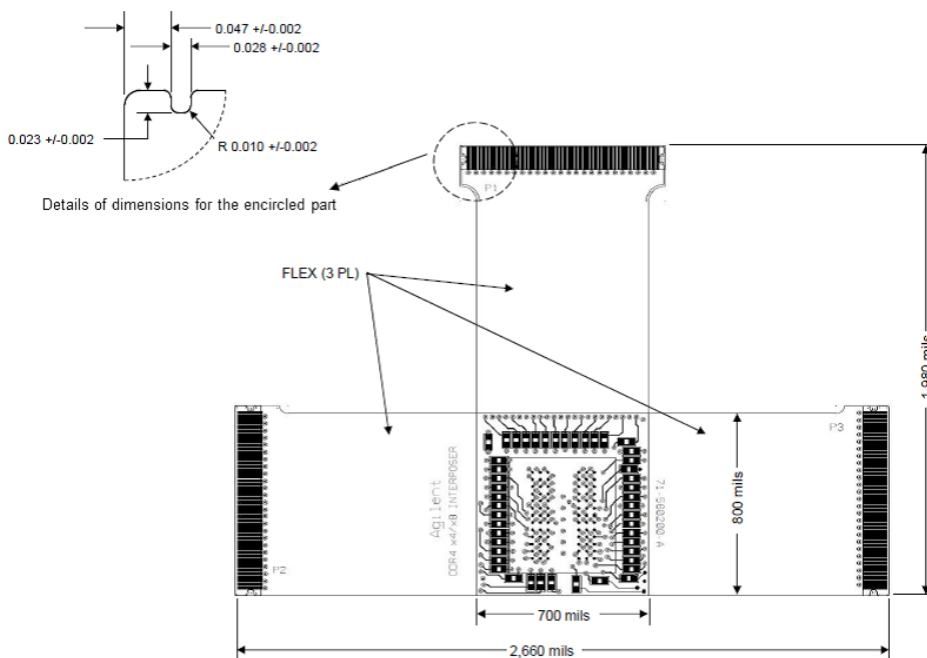
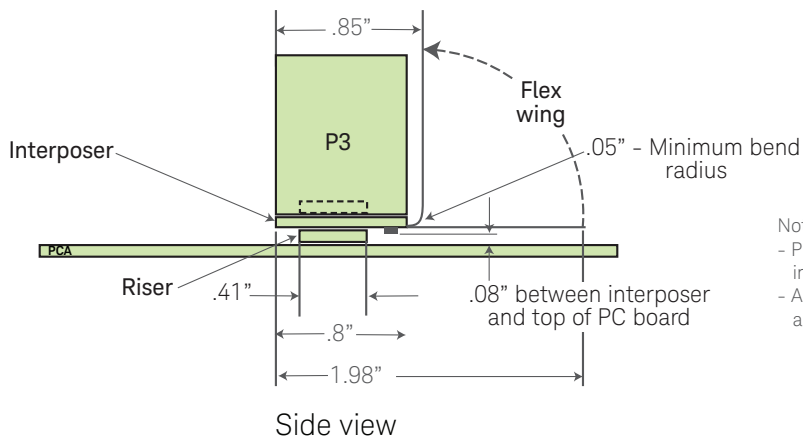
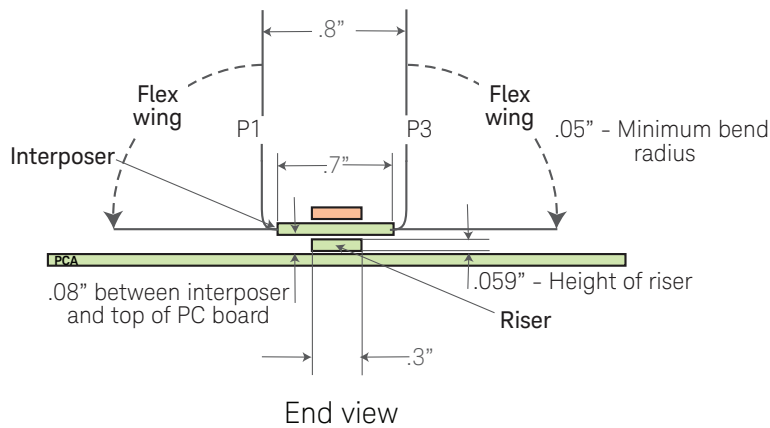

Figure 18. Dimensions of W4633A top view.

# W4633A DDR4, x4/x8, 3-wing BGA Interposer (Continued)

## Dimensional Drawings (Continued)



Notes:  
 - P1, P2, P3 are the interposer wings  
 - All dimensions are normal

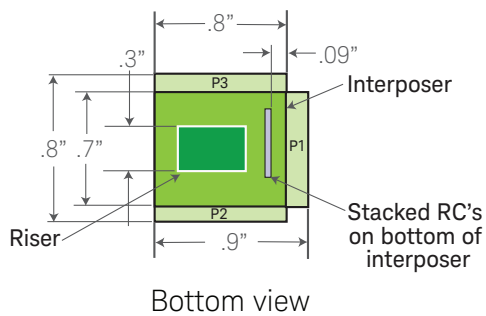

Figure 19a and 19b. End, side and bottom KOV views of W4633A BGA interposer.



## W4633A DDR4, x4/x8, 3-wing BGA Interposer (Continued)

### Dimensional drawings (Continued)

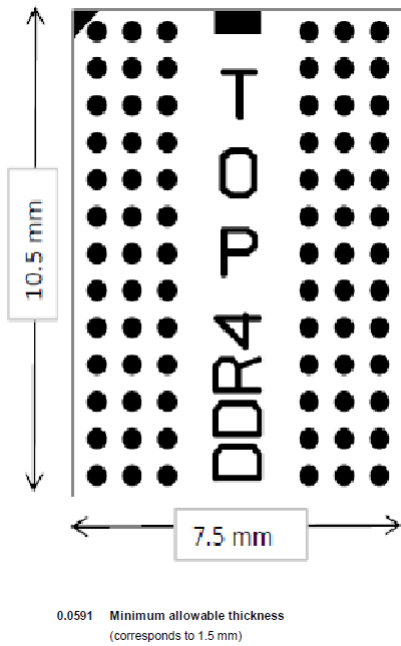

Figure 20. DDR4 x4/x8 riser dimensions.

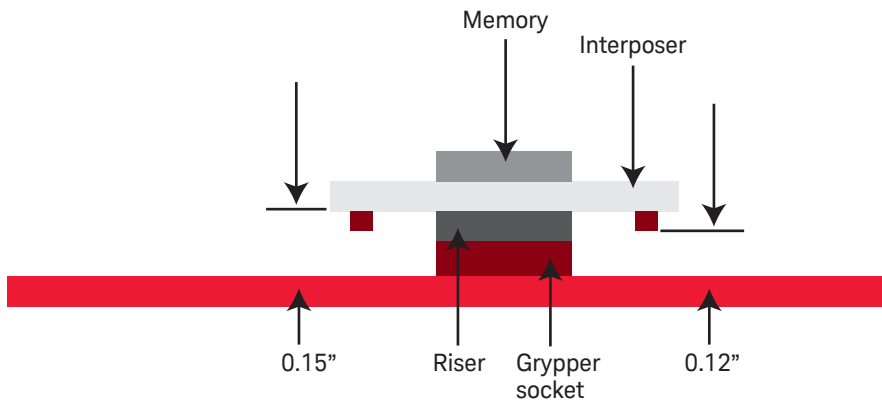

Figure 21. W4633A DDR4 x16 BGA interposer with riser plus optional grypper socket underneath.

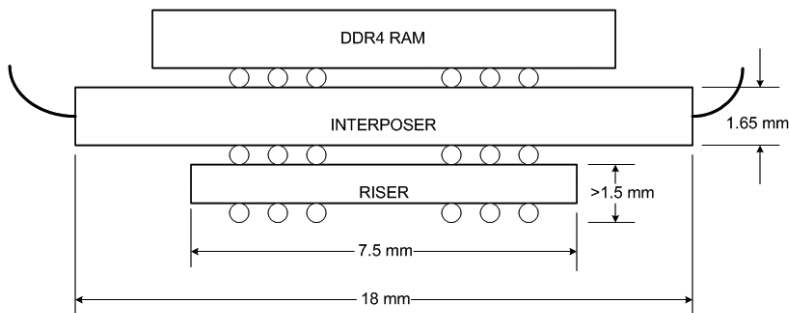

Figure 22. Dimensional diagram of W4633A x4/x8 interposer/RAM stack-up. (Either riser (included) or optional grypper socket (not included) are required.)

# W4631A DDR4 x16, 4-wing BGA Interposer

## Technical Characteristics

### Description

The Keysight Technologies W4631A DDR4, x16, 4-wing BGA interposers are designed to capture DDR4 ADD/CMD/DQ/DQS at data rates of at least 3.2 Gb/s. The W4631A is a rigid/flex BGA interposer that enables probing of chip down DDR4 DRAM (x16) directly at the ball grid array using Keysight logic analyzers.

#### W4631A DDR4 BGA interposer features

DDR4 device support	DDR4 single-channel x16 DRAM BGA chip
DDR4 data rate support	In excess of 3.2 Gb/s
BGA package footprint support	96-ball, JEDEC MO-207M footprint variation DU-z
BGA package size support	Maximum of 12 mm x 19 mm DDR4 DRAM package can fit on top of the W4631A interposer without an additional riser or optional grypper or other socket to provide clearance for the RC components
Signal-to-signal timing skew	Timing skews are within $\pm 25$ ps
Signal isolation	RC (resistor/capacitor) isolation networks for proper logic analyzer probing are installed on the top and bottom of the W4631A
Connectors	4 zero-insertion force (ZIF) connectors
Form factor	Rigid/flex 4-wing BGA interposer
Logic analyzer compatibility	U4154A/B

W4631A includes

- DDR4 96-ball, x16 4-wing BGA interposer
- 96-ball riser. The riser is required to provide clearance for the interposer's bottom RC networks and surrounding devices. The riser includes a ground plane. Riser orientation is critical for proper operation

W4631A requires either

- One compatible logic analyzer module in a chassis with host controller and either
- Two E5849A ZIF cables to connect between W4631A BGA interposer and compatible logic analyzer
- Or one DDR4 ZIF cable to connect between the W4631A and compatible logic analyzer. (Recommended for all data rates)

Optional for the W4631A

- The DDR4 96-ball riser may be replaced with an optional grypper socket which is sold separately: <http://www.hsiotech.com/products/released-products/engineering-products/grypper-family>

## W4631A DDR4 x16, 4-wing BGA Interposer (Continued)

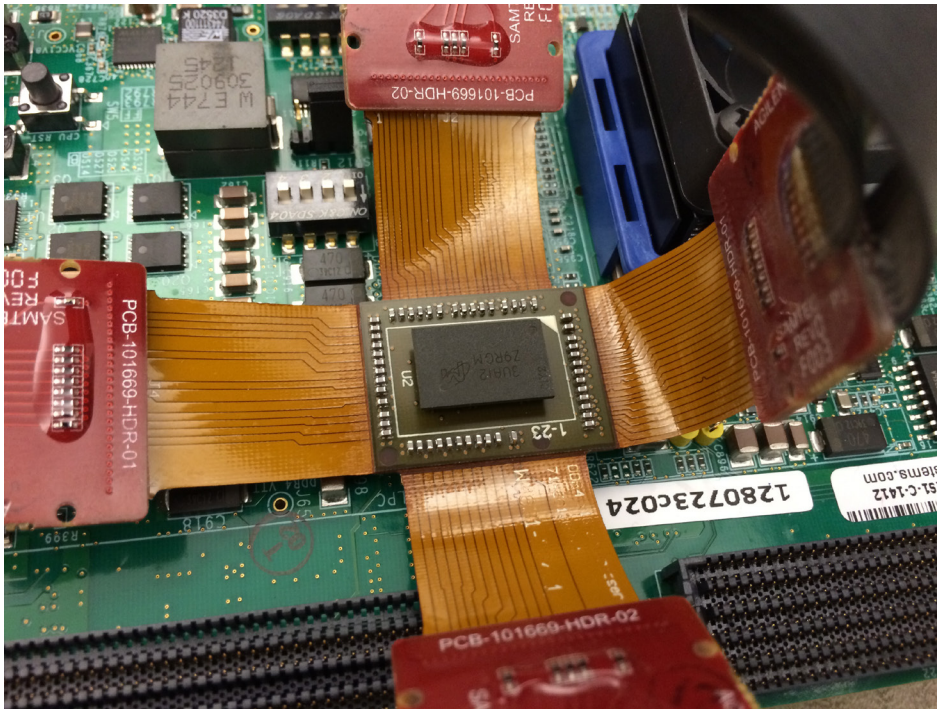

Figure 23. W4631A 4-wing DDR4 x16 BGA interposer connected to two E5849A cables. Note that the ZIF door closes on the bottom side of the wings. This is true for both the W4633A and W4631A DDR4 BGA interposers.

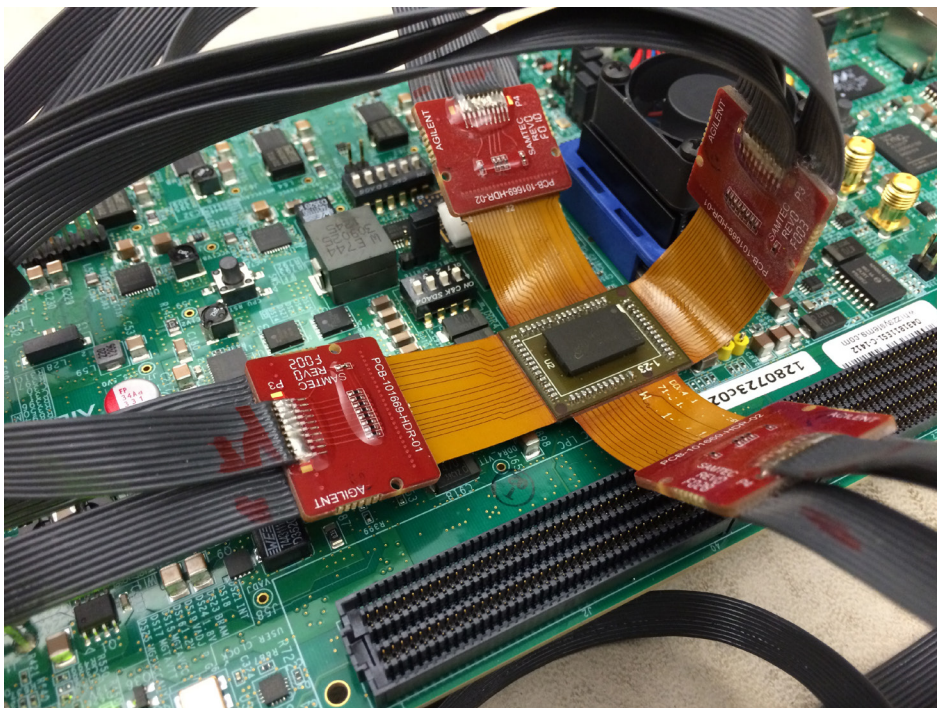

Figure 24. W4631A 4-wing DDR4 x16 BGA interposer connected to one DDR4 x16 ZIF cable. Note that the ZIF door closes on the bottom side of the wings. This is true for both the W4633A and W4631A DDR4 BGA interposers.

## W4631A DDR4 x16, 4-wing BGA Interposer (Continued)

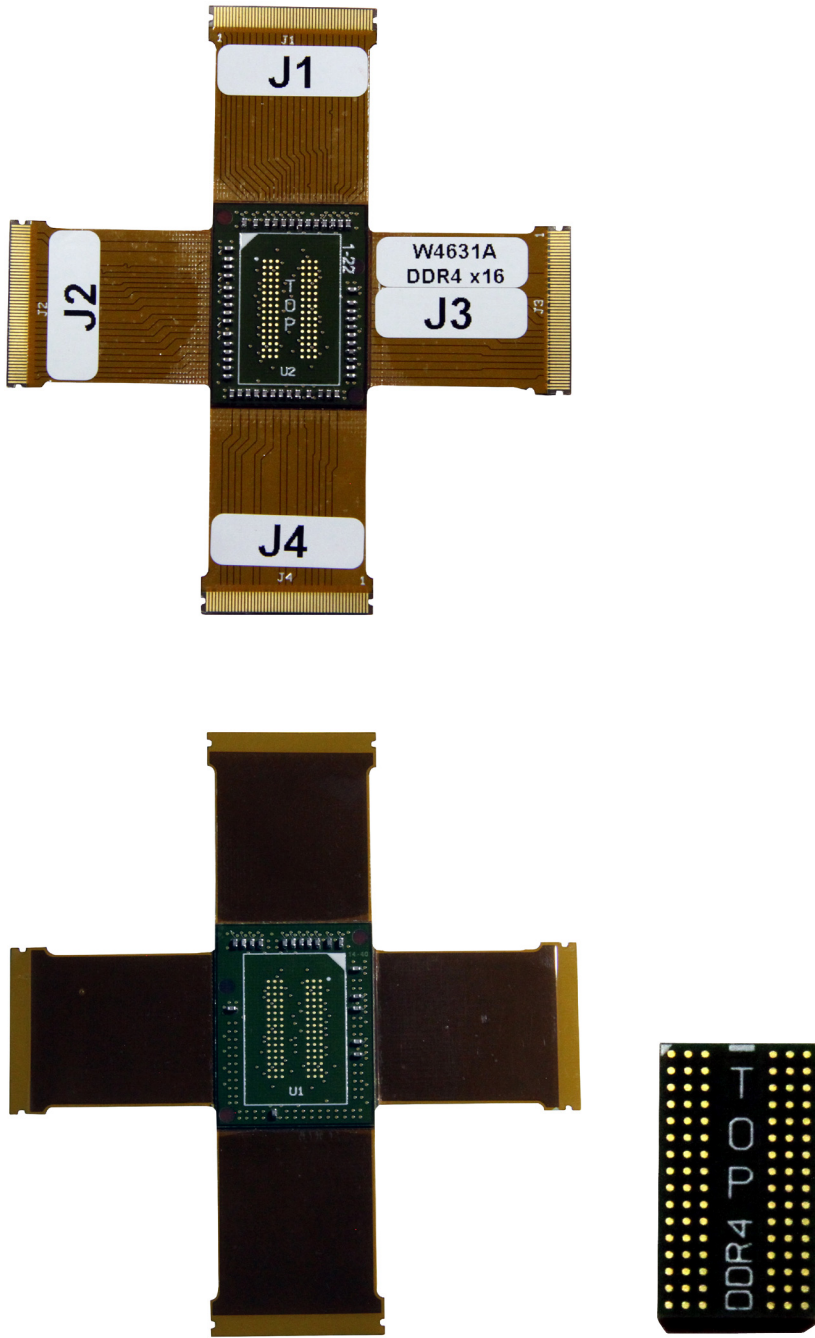

Figure 25. W4631A top and bottom views and DDR4 x16, 96-ball riser.

# W4631A DDR4 x16, 4-wing BGA Interposer (Continued)

## Signals probed

The BGA interposer solutions provide access to the DDR4 signals highlighted below and pass all power and ground signals between the system and memory chip.

W4631A DDR4 x16 Logix Analyzer 4-wing Interposer

	1	2	3	4	5	6	7	8	9	
A	VDDQ	GND	DQU0				DQSU_c	GND	VDDQ	A
B	VPP	GND	VDD				DQSU_t	DQU1	VDD	B
C	VDDQ	DQU4	DQU2				DQU3	DQU5	GND	C
D	VDD	GND	DQU6				DQU7	GND	VDDQ	D
E	GND	DMU_n	GND				DML_n	GND	GND	E
F	GND	VDDQ	DQSL_c				DQL1	VDDQ	ZQ	F
G	VDDQ	DQL0	DQSL_t				VDD	GND	VDDQ	G
H	GND	DQL4	DQL2				DQL3	DQL5	GND	H
J	VDD	VDDQ	DQL6				DQL7	VDDQ	VDD	J
K	GND	CKE	ODT				CK_t	CK_c	GND	K
L	VDD	A14	ACT_n				CS_n	A16	VDD	L
M	VREFCA	BG0	A10				A12	A15	GND	M
N	GND	BA0	A4				A3	BA1	TEN	N
P	RST_n	A6	A0				A1	A5	ALERT_n	P
R	VDD	A8	A2				A9	A7	VPP	R
T	GND	A11	PAR				NC	A13	VDD	T
	1	2	3	4	5	6	7	8	9	

DATA			CA	Command/Address
CLOCK	(Clock inputs on Logic Analyzer)		CA	Command/Address
POWER	Not probed		CK	Master clock
OTHER	Not probed			

Figure 26. W4631A DDR4 x16 BGA interposer signals probed; Top view.

## Signal access

All signals, including power and ground signals, are passed between the system and memory chip.

DDR4 signal group	Logic analyzer signal access
Address	All
Control and other signals	All except VREFCA, TEN, ZQ
Data	All
Power	DDR4 device power is not monitored by the logic analyzer. Power is passed through the interposer through vias
Ground	Interposer includes multiple ground planes

For additional installation information, refer to the W4630A Series installation guide at <http://literature.cdn.keysight.com/litweb/pdf/W4631-97000.pdf>.

## W4631A DDR4 x16, 4-wing BGA Interposer (Continued)

### W4631A connections to logic analyzer

W4631A connections for < 2.5 Gb/s data rates using two E5849A ZIF probes and default software configuration.

Reference designator	Logic analyzer pods
E5849A Probe 2 Pod A	Pod 1
E5849A Probe 1 Pod C	Pod 2
E5849A Probe 1 Pod A	Pod 3
E5849A Probe 1 Pod B	Pod 5
E5849A Probe 2 Pod B	Pod 7
E5849A Probe 2 Pod C	Pod 8

W4631A connections for < > 2.5 Gb/s data rates using one DDR4 x16 ZIF and default software configuration.

Reference designator	Logic analyzer pods
DDR4 x16 Probe Pod D	Pod 1
DDR4 x16 Probe Pod E	Pod 2
DDR4 x16 Probe Pod B	Pod 3
DDR4 x16 Probe Pod A	Pod 5
DDR4 x16 Probe Pod C	Pod 7

### Configuration considerations

- Requires riser or optional (not included) grypper socket between system under test and BGA interposer.
- Requires APS (Advanced Probe Settings) enabled on logic analyzer to enable data rate captures over 1866 Mb/s.

# W4631A DDR4 x16, 4-wing BGA Interposer (Continued)

## Dimensional Drawings

DDR4 x16 Rigid/Flex Logic Analyzer Interposer

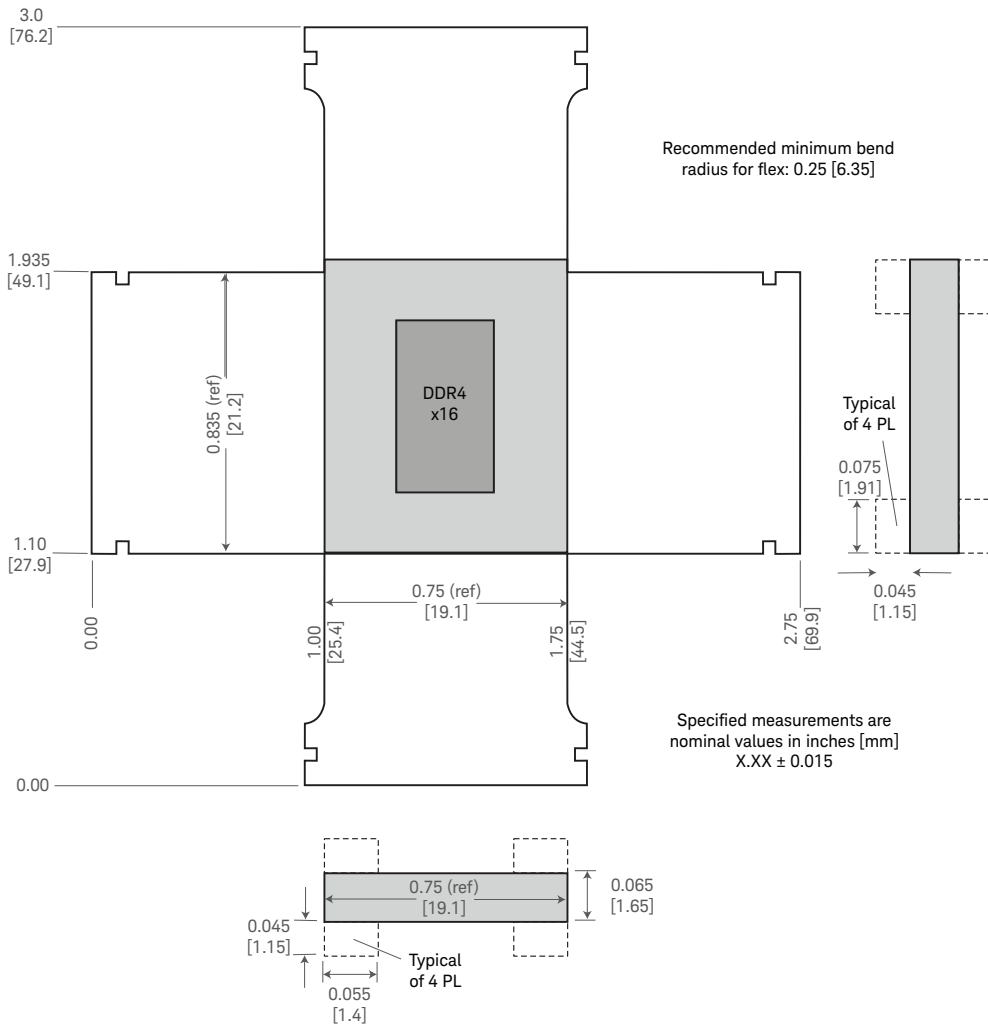
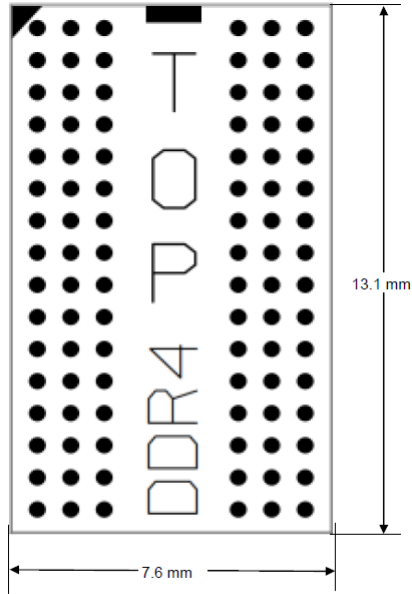

Figure 27. W4631A DDR4 x16 BGA interposer dimensional diagram.

## W4631A DDR4 x16, 4-wing BGA Interposer (Continued)

### Dimensional Drawings (Continued)



0.0591 Minimum allowable thickness  
(corresponds to 1.5 mm)

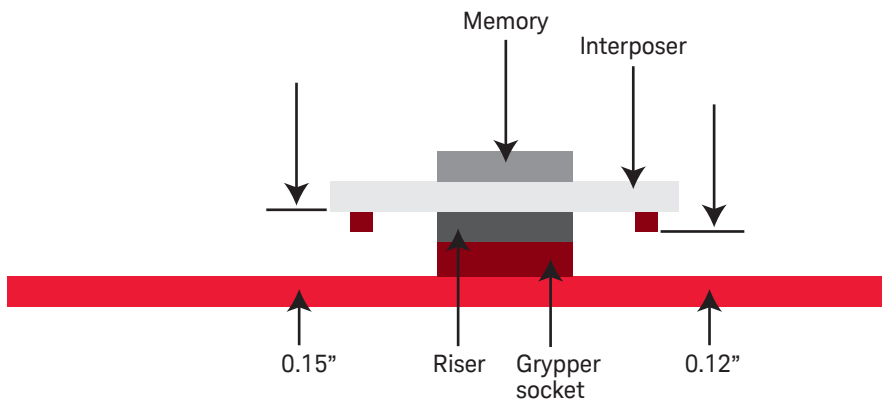

Figure 28. W4631A DDR4 x16 BGA interposer with riser plus optional grypper socket underneath.



# W4636A DDR4 x16, 2-wing BGA Interposer

## Technical Characteristics

### Description

The W4636A DDR4 x16 – 2 wing BGA interposer for 96 ball DDR4 DRAM is designed for data rates up to and including 2.4 Gb/s. The W4636A probes all ADD/CMD/CNTRL and partial DQ/DQS. The W4636A is designed for minimal KOV for space-limited systems under test. The W4636A is the least expensive DDR4 x16 BGA interposer for use with a logic analyzer.

<b>W4636A DDR4 BGA interposer features</b>	
DDR4 device support	DDR4 single-channel x16 DRAM BGA chip
DDR4 data rate support	Up to and including 2.4 Gb/s
BGA package footprint support	96-ball, JEDEC MO-207M footprint variation DU-z
BGA package size support	Maximum of 12 mm x 19 mm DDR4 DRAM package can fit on top of the W4636A interposer without an additional riser or optional grypper or other socket to provide clearance for the RC components
Signal-to-signal timing skew	Timing skews are within $\pm 25$ ps
Signal Isolation	RC (resistor/capacitor) isolation networks are not on the W4636A interposer. RC networks are on the E5847A ZIF cables
Connectors	Two zero-insertion force (ZIF) connectors
Form factor	Rigid/flex 2-wing BGA interposer for minimal KOV. Use for space-limited systems under test
Logic analyzer compatibility	U4154A/B

W4636A includes

- DDR4 96-ball, x16 2-wing BGA interposer
- Note: W4636A interposers do not include or require risers

W4636A requires

- One E5847A ZIF cable to connect between W4636A BGA interposer and compatible logic analyzer
- One compatible logic analyzer module in a chassis with host controller

Optional for the W4636A

- An optional grypper socket, sold separately, can be used with the W4636A:  
<http://www.hsiotech.com/products/released-products/engineering-products/grypper-family>

## W4636A DDR4 x16, 2-wing BGA Interposer (Continued)

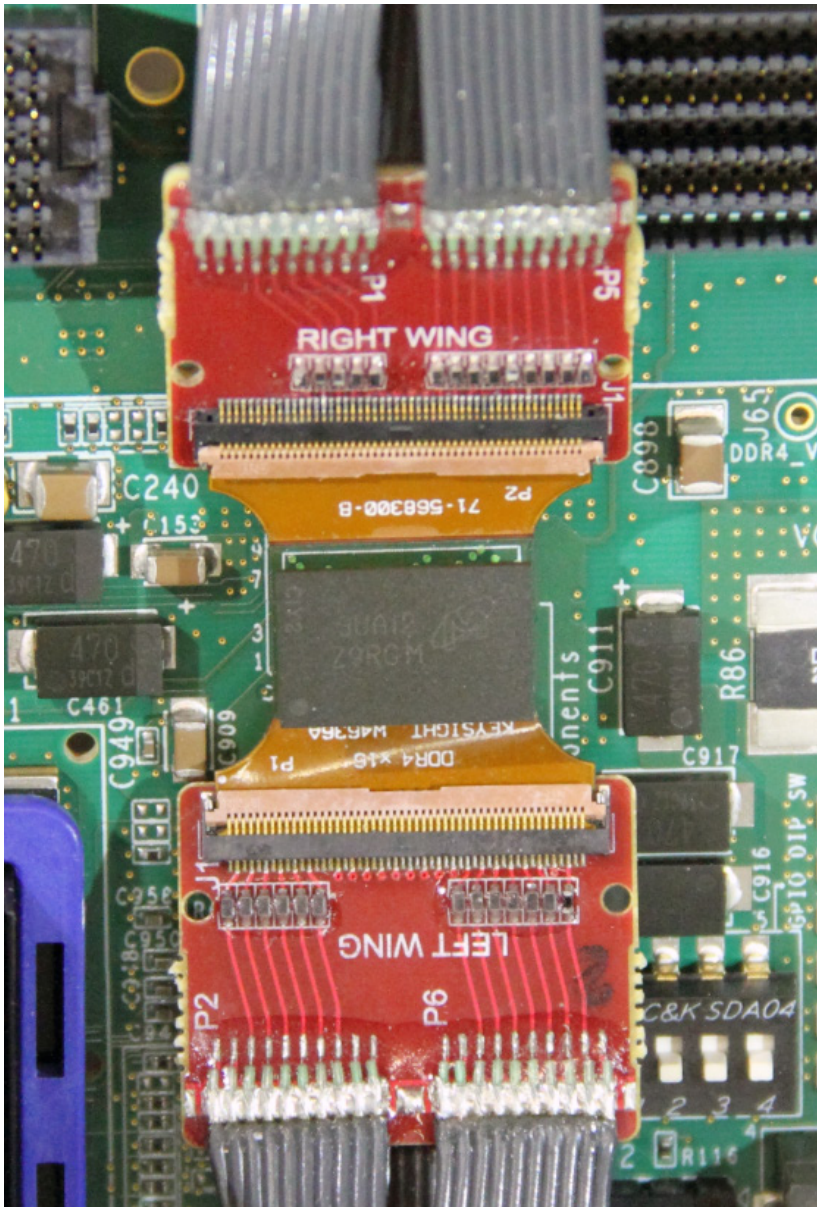

Figure 29. W4636A with E5847A ZIF connectors attached to the wings. Note: “Left Wing” ZIF paddle of E5847A connects to P1 on the W4636A and “Right Wing” ZIF paddle on E5847A connects to P2 on the W4636A. Orientation of ZIF door to W4636A wing is with ZIF door on top side of wing.

## W4636A DDR4 x16, 2-wing BGA Interposer (Continued)

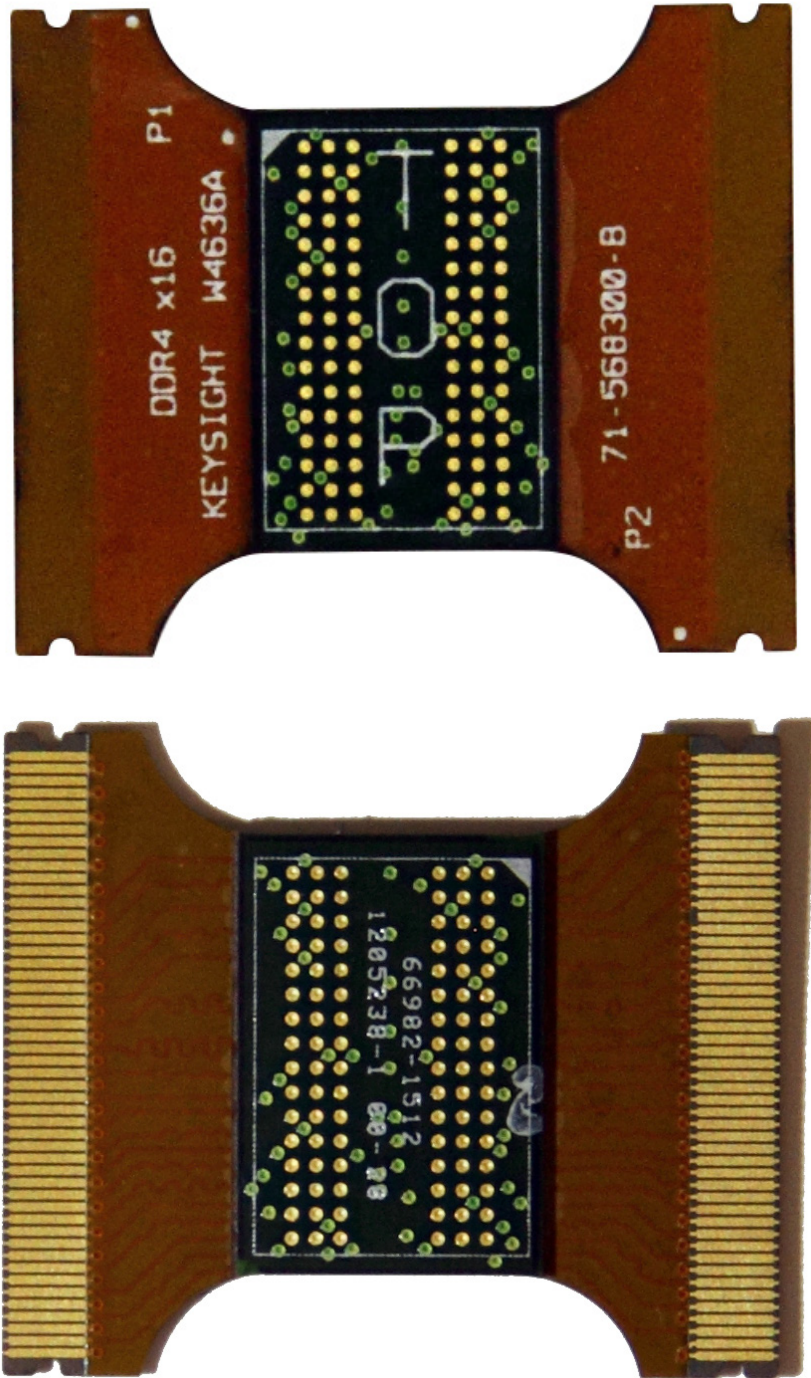

Figure 30. W4636A top and bottom views. (W4636A does not include or require a riser.)

# W4636A DDR4 x16, 2-wing BGA Interposer (Continued)

## Signals probed

The BGA interposer solutions provide access to the DDR4 signals highlighted below and pass all power and ground signals between the system and memory chip.

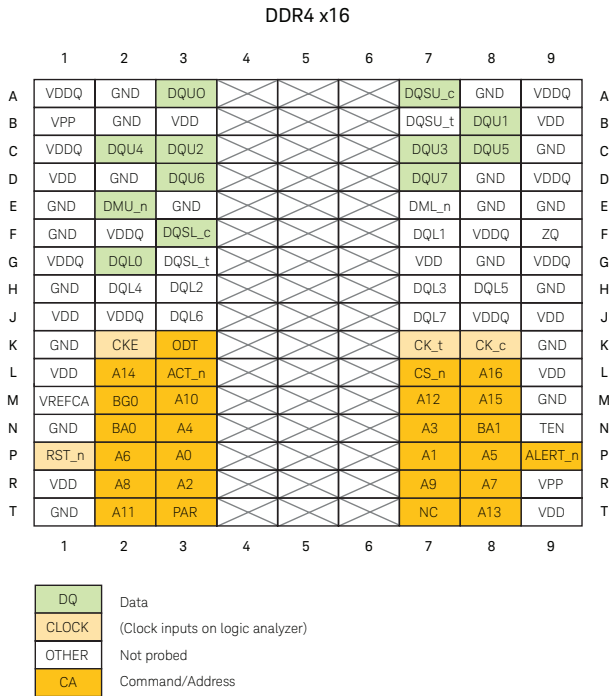

Figure 31. W4636A DDR4 x16 BGA interposer signals probed; Top view.

## Signal access

All signals, including power and ground signals, are passed between the system and memory chip.

DDR4 signal group	Logic analyzer signal access
Address	All
Control and other signals	All except VREFCA, TEN, ZQ
Data	All
Power	DDR4 device power is not monitored by the logic analyzer. Power is passed through the interposer through vias
Ground	Interposer includes multiple ground planes

## W4636A connections to logic analyzer

W4636A connections for < 2.4 Gb/s data rates using one E5847A ZIF probe and default software configuration.

Reference designator	Logic analyzer pods
E5847A Pod B	Pod 1
E5847A Pod A	Pod 3
E5847A Pod C	Pod 7

## Configuration considerations

- No riser or grypper socket between system under test and BGA interposer required. Use of riser or grypper socket is optional and neither are included with the W4636A.
- Requires APS (Advanced Probe Settings) enabled on logic analyzer to enable data rate captures over 1866 Mb/s.

# W4636A DDR4 x16, 2-wing BGA Interposer (Continued)

## Dimensional Drawings

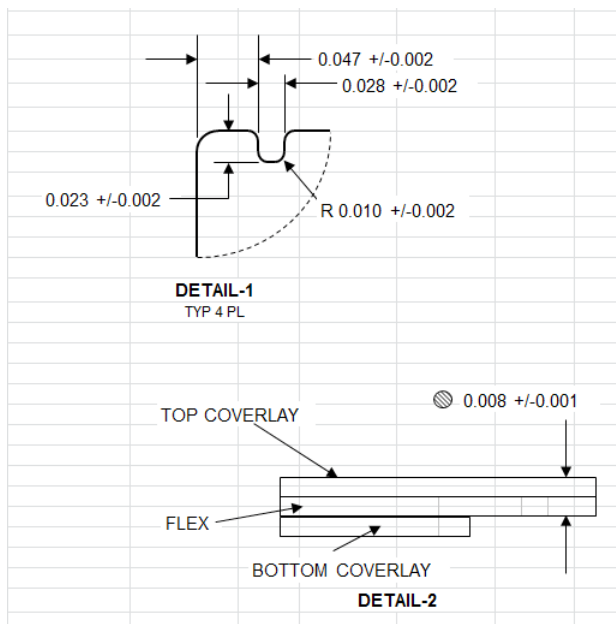
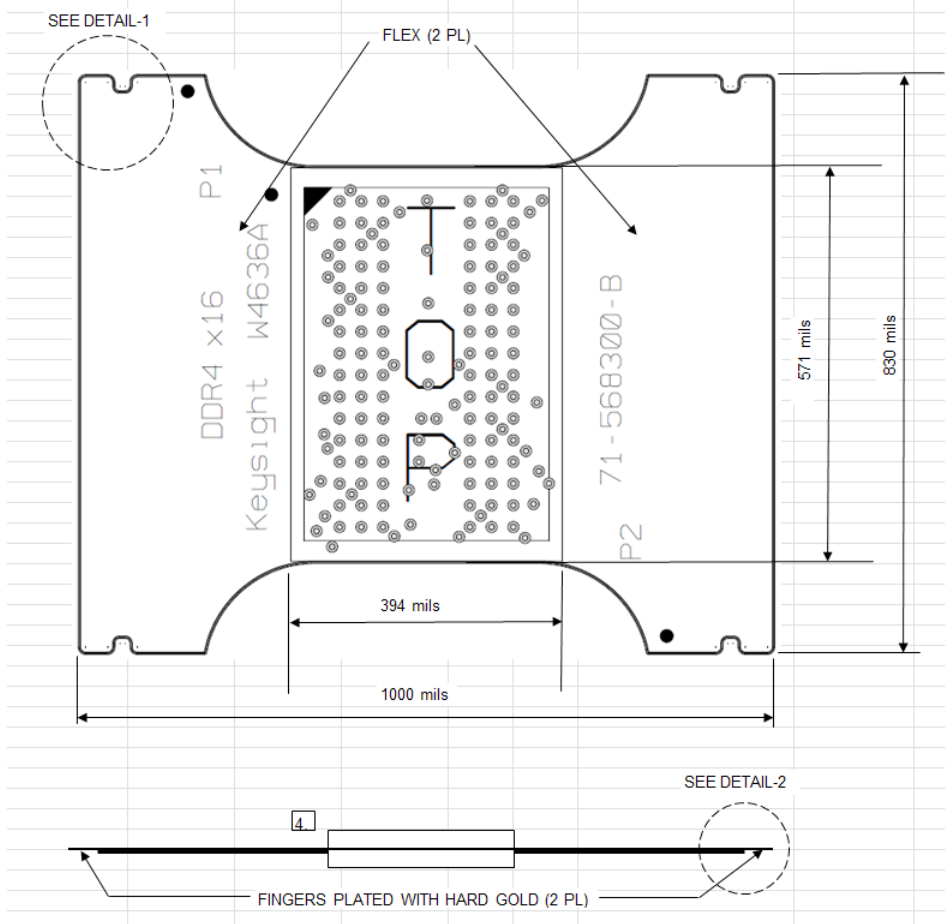

Figure 32. W4636A DDR4 x16 2-wing BGA interposer dimensions; Top view.

## DDR EyeFinder and EyeScan Software

The DDR EyeFinder and EyeScan software tool helps you position the sampling points for accurate read and write data capture. The software qualifies scans of valid read and write commands while your system executes memory tests, random read and write traffic, or stimulus program. The software will then display read and write data valid window as a result of the scan. DDR Eyefinder and EyeScan software is compatible with all W4630A Series BGA interposers.

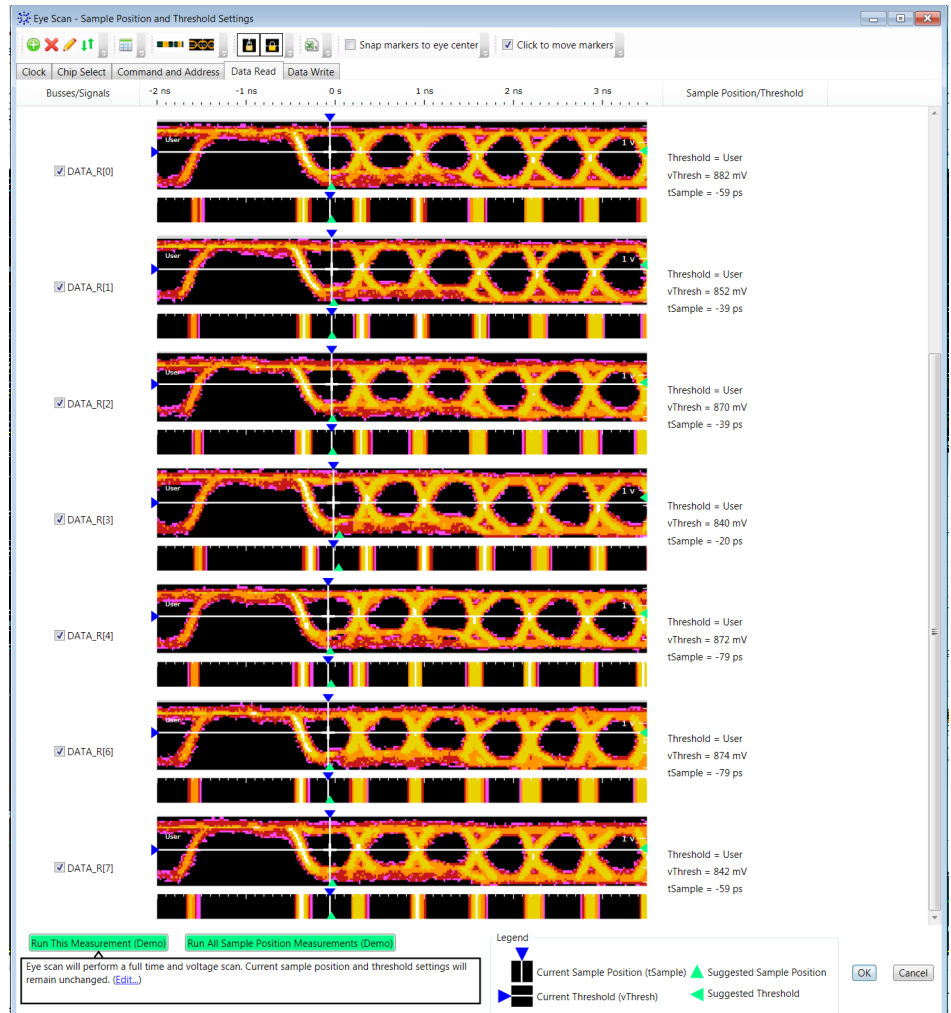

Figure 33. DDR EyeFinder and Eyescan software shows read and write data valid windows for accurate sampling position of data for protocol decode.

## Optional Software

### B4661A memory analysis software

The Keysight B4661A memory analysis software offers a suite of tools that include the industry's first protocol compliance violation testing capability across speed changes, a condensed traffic overview for rapid navigation to areas of interest in the logic analyzer trace, powerful performance analysis graphics, and DDR and LPDDR decoders. With the B4661A memory analysis software and a Keysight logic analyzer, users can monitor DDR3/4 or LPDDR2/3/4 systems to debug, improve performance, and validate protocol compliance. Powerful traffic overviews, multiple viewing choices, and real-time compliance violation triggering help identify elusive DDR/LPDDR system violations. The Keysight B4661A memory analysis software provides four standard software features and four licensed memory analysis options.

#### B4661A standard software features

- Default configurations for DDR and LPDDR probing solutions for Keysight logic analyzers
- DDR setup assistant
- DDR eye finder/eye scan
- DDR configuration creator

#### B4661A licensed software options

- DDR decoder with physical address trigger tool (B4661A-1xx)
- LPDDR decoder (B4661A-2xx)
- DDR and LPDDR compliance violation analysis (B4661A-3xx) post-process compliance violation analysis real-time compliance violation analysis
- DDR3/4 and LPDDR2/3/4 performance analysis (B4661A-4xx)

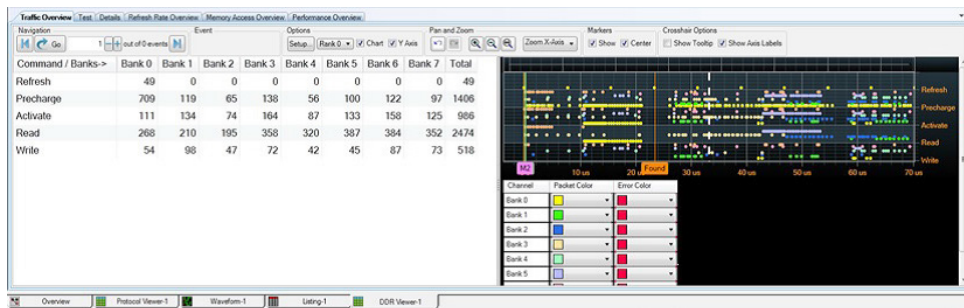

Figure 34. Traffic overview example: graphing command activity by commands and banks across the captured trace from the Keysight logic analyzer.

## Optional Software (Continued)

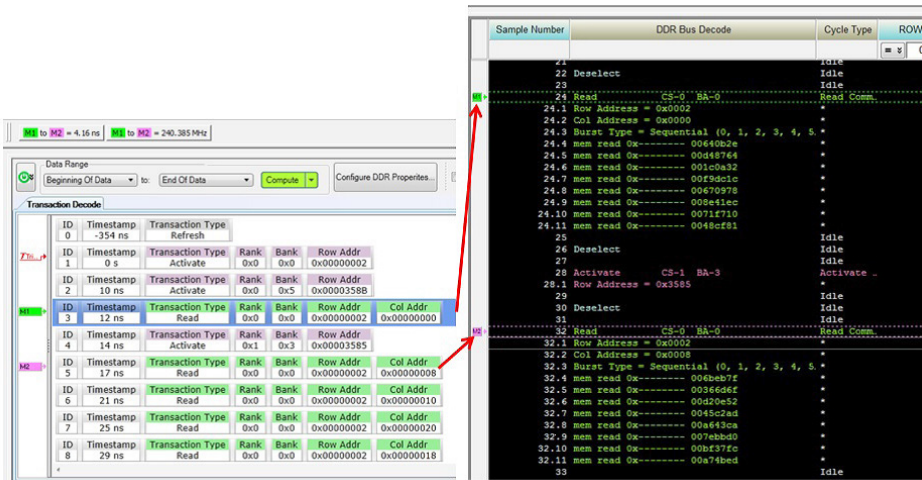

Figure 35. Transaction decode provides a high-level view that is time-correlated to the listing window where the more detailed DDR bus decoder results are viewed. (The transaction decode also includes a details window to see the data associated with each read or write transaction.)

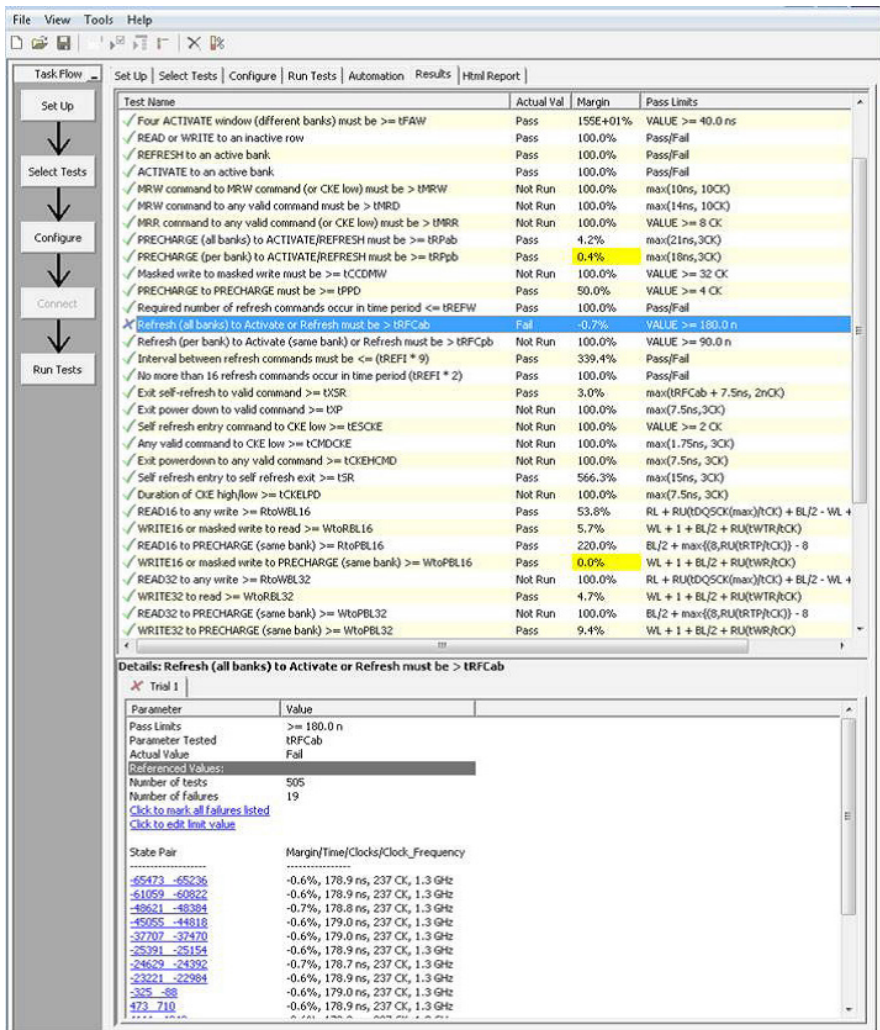
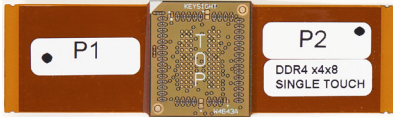
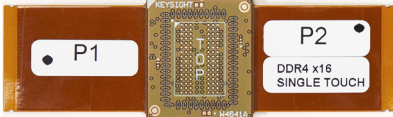

Figure 36. The post-process compliance tool includes hyperlinks to quickly jump to and/or mark violations and worst-case violations in the logic analyzer traces, transaction overview, and listing windows.



# DDR4 BGA Interposer and Cabling Selection Guide

## W4640A Series DDR4 BGA Interposer and Cabling Selection Guide

DDR4 BGA interposer	Description	Photo	Model and quantity of ZIF cable(s) required per DDR4 BGA interposer	Compatible logic analyzers and quantity per DDR4 BGA interposer
W4643A	DDR4 x4/x8 - 2 wing BGA interposer for 78 ball DDR4 DRAM. Designed for data rates in excess of 3.2 Gb/s. Captures all ADD/CMD/DQ/DQS.		Qty (1) U4208A Qty (1) U4209A	<ul style="list-style-type: none"> <li>– (1) U4164A logic analyzer</li> <li>– (1) option -02G for all data rates <sup>1</sup></li> </ul>
W4641A	DDR4 x16 - 2 wing BGA interposer for 96 ball DDR4 DRAM. Designed for data rates in excess of 3.2 Gb/s. Captures all ADD/CMD/DQ/DQS.		Qty (1) U4208A Qty (1) U4209A	<ul style="list-style-type: none"> <li>– (1) U4164A logic analyzer</li> <li>– (1) option -02G for all data rates <sup>1</sup></li> </ul>

1. Hardware configurations are unchanged for all DDR4 data rates. W4640A Series DDR4 BGA interposers are designed to be used with quad sample state mode on the U4164A logic analyzer module to attain the highest data rate captures with the least probe loading.

## W4630A Series DDR4 BGA Interposer and Cabling Selection Guide

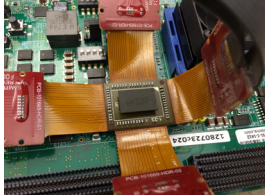
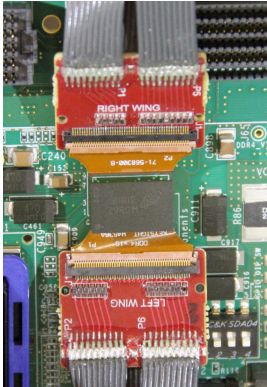
DDR4 BGA interposer	Description	Photo	Quantity and type of ZIF cable(s) required per DDR4 BGA interposer	Quantity of U4201A logic analyzer cables required per DDR4 interposer	Quantity of compatible logic analyzer modules per DDR4 BGA interposer
W4633A	DDR4 x4/x8, - 3-wing BGA interposer for 78 ball DDR4 DRAM. Designed for data rates up to and including 3.2 Gb/s. Captures all ADD/CMD/DQ/DQS		2 E5849A DDR4 ZIF cables	4	1 U4164A or U4154A/B for all data rates <sup>1</sup>
W4631A	DDR4 x16, - 4-wing BGA interposer for 96 ball DDR4 DRAM. Designed for data rates up to and including 3.2 Gb/s. Captures all ADD/CMD/DQ/DQS		2 E5849A DDR4 ZIF cables	4	1 U4164A or U4154A/B for data rates up to and including 2.5 Gbs
			1 DDR4 x16 ZIF cable ordered through Keysight AEO	6	2 U4164A or U4154A/B for data rates over 2.5 Gb/s
W4636A	DDR4 x16, - 2-wing BGA interposer for 96 ball DDR4 DRAM. Designed for data rates up to and including 2.4 Gb/s. Captures all ADD/CMD and partial DQ/DQS. Designed for minimal KOV for space limited systems under test		1 E5847A ZIF cable	3	1 U4164A or U4154A/B

1. Hardware configuration is unchanged for data rates under or over 2.5 Gb/s. However, software configuration does change. Use DDR setup assistant to select proper software configuration for system under test.

# Logic Analyzer Configuration Guide and Ordering Information

## W4640A Series DDR4 BGA Interposer Configuration Guide and Ordering Information

DRAM type	Data width	Signal access to interposer	interposer	Probe/cables (qty)	Compatible logic analyzer module(s) and model option(s)	Order summary
<b>W4643A x4/x8 2-wing, 3.2 Gb/s</b>						
X4	X4	Command, Address,	W4643A	U4164A with option -02G	U4164A with option -02G	U4164A (1) <sup>1</sup>
X8	X8	Control and Data				U4164A -02G (1) U4208A (1) U4209A (1) W4643A (1)
<b>W4641A x16 2-wing, 3.2 Gb/s</b>						
X16	X16	Command, Address,	W4641A	U4208A (1) U4209A (1)	U4164A with option -02G	U4164A (1) <sup>1</sup> U4164A -02G (1) U4208A (1) U4209A (1) W4641A (1)

1. U4164A requires M9502A or M9505A AXIe chassis and host controller.

## W4630A Series DDR4 BGA Interposer Configuration Guide and Ordering Information

DRAM type	Data width	Signal access to interposer	Interposer	Cables (qty)	Compatible logic analyzer module(s)	Order summary
<b>W4633A x4/x8 - 3 wing BGA interposer</b>						
x4	x4	Command, Address,	W4633A	E5849A (2) U4201A (4)	U4164A U4154A/B	<b>Model (qty)</b> U4164A (1) <sup>1</sup> U4201A (4) E5849A (2) W4631A (1)
x8	x8	Control and Data				
<b>W4631A x16 - 4 wing BGA interposer</b>						
x16	x16	Command, Address,	W4631A	E5849A (2) U4201A (4)	U4164A U4154A/B	U4164A (1) <sup>2</sup> U4201A (4) E5849A (2) <sup>2</sup> (or optional DDR4 x16 ZIF cable (1))
<b>W4636A x16 - 2 wing BGA interposer</b>						
x16	x16	Command, Address,	W4636A	E5847A (1) U4201A (3)	U4164A U4154A/B	U4164A (1) U4201A (3) E5847A (1) W4636A (1)

1. U4164A, and U4154A/B require M9502A or M9505A AXIe chassis and host controller.

2. For data rates under 2.5 Gb/s, connection of the W4631A with two E5849A cables fan out to connect to one logic analyzer module using four U4201A cables. For data rates over 2.5 Gb/s, the W4631A configuration with two E5849A cables requires two U4154A/B modules. For operation over 2.5 Gb/s, a single DDR4 x16 ZIF cable is recommended, as that configuration only requires a single logic analyzer module for data rates under or over 2.5 Gb/s. The DDR4 x16 ZIF cable is available through the Keysight AEO specialty probe process.

## Related Products

Product	Description
<b>Modular logic analyzers</b>	
U4164A	36-channel, up to 4 Gb/s state, quad state mode, up to 10 GHz timing, memory depth up to 400 M, AXIe-based logic analyzer module allowing three modules to merge into one time base
U4154B	136-channel, 4 Gb/s state, 5 GHz timing, memory depth up to 200 M, AXIe-based logic analyzer module allowing three modules to merge into one time base
U4201A (4)	Logic analyzer probe cable
<b>Logic analyzer ZIF probes<sup>1</sup></b>	
E5849A (2)	46-ch single-ended ZIF probe for x4/x8 DRAM BGA interposer connect to 90-pin logic analyzer cable
<b>Software</b>	
Logic and protocol analyzer software	Required - not licensed; acts as the base software platform
B4621B	DDR2/3/4 bus decoder (recommended)
B4622B	DDR2/3/4 and LPDDR/2/3 protocol compliance and analysis tool (recommended)
DDR Setup Assistant and DDR Eyefinder <sup>2</sup>	Highly recommended, no cost

1. Used to connect W4631A or W4633A DDR4 BGA interposers to 90 pin logic analyzer cables.
2. DDR Setup Assistant and Eyefinder software is available free of charge. DDR Setup Assistant provides a series of steps to simplify state mode measurement tuning with U4154A/B logic analyzer modules.

You can install the software components by downloading the required files from [www.keysight.com/find/la-sw-download](http://www.keysight.com/find/la-sw-download)

## Related Literature

Publication title	Pub number
W4640A and W4630-Series DDR4 DRAM BGA Interposers - Installation Guide	W4631-97000
Probing Solutions for Logic Analyzers - Data Sheet	5968-4632E
A Time-Saving Method for Analyzing Signal Integrity in DDR Memory Buses - Application Note	5989-6664EN
Infiniium 90000 X-Series Oscilloscopes - Data Sheet	5990-5271EN
Capture Highest DDR3 Data Rates Using Advanced Probe Settings on Logic Analyzers - Technical Brief	5991-0799EN
B4621B for DDR2, DDR3, or DDR4 Debug and Validation - Data Sheet	5991-0802EN
B4622B DDR/2/3/4 and LPDDR/2/3 Protocol Compliance and Analysis Toolset - Data Sheet	5991-1063EN
U4154B 4 Gb/s State Mode Logic Analyzer Module - Data Sheet	5992-0108EN
B4661A Memory Analysis Software for Logic Analyzers - Data Sheet	5992-0984EN
U4164A 4 Gb/s State Mode Logic Analyzer Module - Data Sheet	5992-1057EN



[www.axiestandard.org](http://www.axiestandard.org)

AdvancedTCA® Extensions for Instrumentation and Test (AXIe) is an open standard that extends the AdvancedTCA for general purpose and semiconductor test. Keysight is a founding member of the AXIe consortium. ATCA®, AdvancedTCA®, and the ATCA logo are registered US trademarks of the PCI Industrial Computer Manufacturers Group.



[www.lxistandard.org](http://www.lxistandard.org)

LAN eXtensions for Instruments puts the power of Ethernet and the Web inside your test systems. Keysight is a founding member of the LXI consortium.



[www.pxisa.org](http://www.pxisa.org)

PCI eXtensions for Instrumentation (PXI) modular instrumentation delivers a rugged, PC-based high-performance measurement and automation system.

## Evolving Since 1939

Our unique combination of hardware, software, services, and people can help you reach your next breakthrough. We are unlocking the future of technology.

From Hewlett-Packard to Agilent to Keysight.



For more information on Keysight Technologies' products, applications or services, please contact your local Keysight office. The complete list is available at: [www.keysight.com/find/contactus](http://www.keysight.com/find/contactus)

### Americas

Canada	(877) 894 4414
Brazil	55 11 3351 7010
Mexico	001 800 254 2440
United States	(800) 829 4444

### Asia Pacific

Australia	1 800 629 485
China	800 810 0189
Hong Kong	800 938 693
India	1 800 11 2626
Japan	0120 (421) 345
Korea	080 769 0800
Malaysia	1 800 888 848
Singapore	1 800 375 8100
Taiwan	0800 047 866
Other AP Countries	(65) 6375 8100

### Europe & Middle East

Austria	0800 001122
Belgium	0800 58580
Finland	0800 523252
France	0805 980333
Germany	0800 6270999
Ireland	1800 832700
Israel	1 809 343051
Italy	800 599100
Luxembourg	+32 800 58580
Netherlands	0800 0233200
Russia	8800 5009286
Spain	800 000154
Sweden	0200 882255
Switzerland	0800 805353
	Opt. 1 (DE)
	Opt. 2 (FR)
	Opt. 3 (IT)
United Kingdom	0800 0260637

For other unlisted countries: [www.keysight.com/find/contactus](http://www.keysight.com/find/contactus) (BP-9-7-17)

**DEKRA Certified**  
ISO 9001 Quality Management System

[www.keysight.com/go/quality](http://www.keysight.com/go/quality)  
Keysight Technologies, Inc.  
DEKRA Certified ISO 9001:2015  
Quality Management System

### myKeysight

#### myKeysight

[www.keysight.com/find/mykeysight](http://www.keysight.com/find/mykeysight)

A personalized view into the information most relevant to you.

[www.keysight.com/find/emt\\_product\\_registration](http://www.keysight.com/find/emt_product_registration)

Register your products to get up-to-date product information and find warranty information.

### KEYSIGHT SERVICES

Accelerate Technology Adoption.  
Lower costs.

#### Keysight Services

[www.keysight.com/find/service](http://www.keysight.com/find/service)

Keysight Services can help from acquisition to renewal across your instrument's lifecycle. Our comprehensive service offerings—one-stop calibration, repair, asset management, technology refresh, consulting, training and more—helps you improve product quality and lower costs.



#### Keysight Assurance Plans

[www.keysight.com/find/AssurancePlans](http://www.keysight.com/find/AssurancePlans)

Up to ten years of protection and no budgetary surprises to ensure your instruments are operating to specification, so you can rely on accurate measurements.

#### Keysight Channel Partners

[www.keysight.com/find/channelpartners](http://www.keysight.com/find/channelpartners)

Get the best of both worlds: Keysight's measurement expertise and product breadth, combined with channel partner convenience.



Unlocking Measurement Insights

This information is subject to change without notice.  
© Keysight Technologies, 2017  
Published in USA, December 1, 2017  
5991-4258EN  
[www.keysight.com](http://www.keysight.com)