

Keysight Technologies

Scienlab Dynamic DC Emulator

48 V Series

SL1045A



Table of Contents

System Description	3
System Options	8
Extended Voltage Range	8
SL 1045A-T01 0-6 V operating range	8
Cabinet Base Option Class	8
SL1042A-701 Base stand	8
SL1042A-702 Rollers	8
Service Options.....	8
HS0003A-100 Project Management	8
R9001A-201 Installation Service.....	8
R9001A-202 Start-up Assistance Service.....	9
HS0002A - Productivity Support Service	9

System Description

The Dynamic DC Emulator (DCE) is an electric system which is designed to emulate e.g. batteries for automotive applications. The following voltage, current and power options are available:

Voltage	0-60 V or 6-60 V			
Current options	300 A	600 A	1200 A	
Power options	18 kW	22 kW	22 kW	44 kW

Voltage	0-80 V or 6-80 V				
Current options	300 A	600 A		1200 A	
Power options	22 kW	22 kW	44 kW	22 kW	44 kW

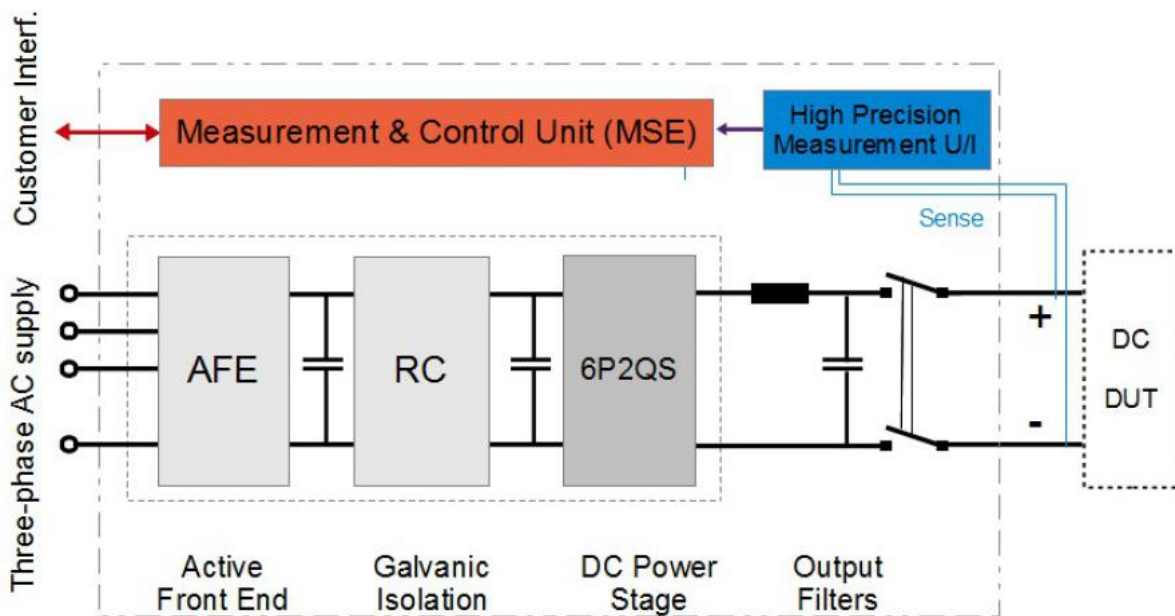

Figure 1: Dynamic DC Emulator system block diagram

Note: The Dynamic DC Emulator can be controlled with Emulator Control which is included in the position “Machine Emulator”.

Controller unit with power stage

- MCU – (Measurement Controller Unit) real-time control module
- Real-time computer controlling electrical output variables
- Including RLC simulation model
- Communication Interface: Ethernet, incl. English interface description

Integrated battery model as per following equivalent circuit diagram:

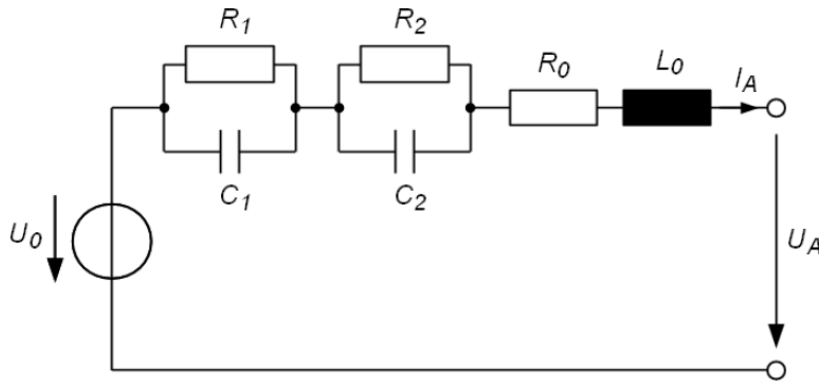

Figure 2: Battery model

The model shall only be active in voltage source operation.

Following parameters may then be set by customer:

- U0: Nominal voltage source value [V]
- R0: Internal voltage source resistance [Ω]
- R1: Resistance within 1st RC link [Ω]
- C1: Capacity within 1st RC link [F]
- R2: Resistance within 2nd RC link [Ω]
- C2: Capacity within 2nd RC link [F]
- L0: Internal inductance [H]

Analog acquisition of voltage and current measuring (4-wire measurement)

	60 V	80 V
Voltage accuracy	$\pm 0.05\%$ of measured value, ± 16 mV (offset)	

	300 A	600 A	1200 A
Current accuracy	$\pm 0.05\%$ of measured value, ± 60 mA (offset)	$\pm 0.05\%$ of measured value, ± 120 mA (offset)	$\pm 0.05\%$ of measured value, ± 240 mA (offset)

- Resolution: 32 Bit (IEEE 754-2008)
- Sample rate: max. 20 kS/s (internal 625 kS/s)
- DC measure and control accuracy are the same

Note: Connecting two systems in parallel has no effect on the voltage accuracy. The offset of the current accuracy is multiplied by two. The error of the measured value [%] is not affected.

Output characteristics

- Voltage ripple: 300 mVeff typ., 500 mVeffmax. at measuring range of 500 kHz

Current options	300 A	600 A	1200 A
Voltage rise time	(10 % → 90 %) : < 5 ms (typ. 2,5 ms) @ 580 μF load		
Voltage stability	< 12 V @ 48V, 0 → 250A < 1ms, 580 μF	< 12 V @ 48V, 0 → 500A < 1ms, 580 μF	< 15 V @ 48V, 0 → 1000A < 1ms, 580 μF

Regenerative Power Stage

Voltage options	60 V	80 V
Source*	5 ... 60 V	5 ... 80 V
Sink*	5 ... 60 V*	5 ... 80 V*

Table 1: Voltage range of 2 quadrant system power stage.

- Modular rack-mounted system, easy to maintain

The default current and voltage ranges are shown in Figure 3 (2 quadrant system).

***Note:** For optional voltage range extension to 0 V ... U_{max} see Figure 4 (4 quadrant system).

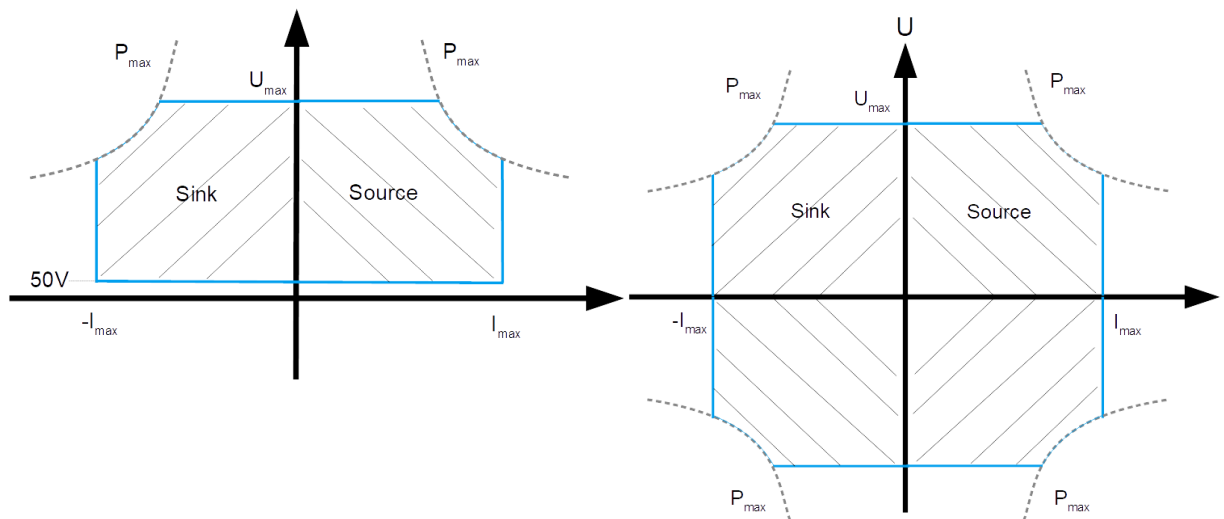

Figure 3: Max. power of 50 V ... U_{max} (2 quadrant system). Figure 4: Max. power of 0 V ... U_{max} (4 quadrant system)

Intrinsic safety

- Intrinsic safe against overheating, overcapacity, short circuit and idling
- Protection against reverse polarity by monitoring the polarity secured by software
- No hardware protection against reverse polarity before output contactors have been closed
- Monitoring of all internal voltages, currents and temperatures
- DC output contactors capable of disconnecting at full load current
- Mains side power contactors ensuring the absence of voltage
- Discharge of all internal high voltage sources upon emergency stop

System cabinet

- Basic dimensions HxWxD: 2.57 m x 0.8 m x 0.8 m placed on rollers plus overlap by switches etc.
- Weight: 450 to 500 kg
- Protection class IP 54
- Control cabinet color: RAL 7035
- Ambient temperature: 10...40 °C
- Air humidity: 30...75% rel. H.
- Sound pressure level according to DIN EN 3744 <70 dB(A) measured at 1 m distance from front

Documentation

- Operating instructions in English
- CE declaration of conformity
- Acceptance and calibration protocol

AFE (Active Front End)

- Regenerative
- Mains recovery (eff. > 90%)
- Idle power compensation $\cos(\varphi) > 0.98$
- HF EMC filter
- 2 kHz filter
- Proof of limits having been respected for line-bound failures within low voltage mains as per EN61000-6-4:2007

Resonance converter

- All-pole isolation of power stages to supply mains

Mains supply

- 3, PE 400 V 50 Hz

System	18 kW	24 kW	44 kW
Back-up fusing provided by customer	50 A gG	63 A gG	125 A gG

- Functional earth (FE)
- Roof-top cable routing with EMC screw connection

System cooling

System	18 kW	24 kW	44 kW
Heat discharge	1.8 kW	2.4 kW	4.4 kW

- Supply flow: $\frac{3}{4}$ ", $\vartheta_Z = 6 \dots 15^\circ\text{C}$
- Return flow: $\frac{3}{4}$ ", $\vartheta_R = \text{max. } 30^\circ\text{C}$
- Max. input pressure 10 bar, without pressure, differential pressure: >1 bar
- Flow control meeting the specific demands
- Max. throughput at full load
- Water stop valve

Safety

- Emergency stop-delay adjustable between 0 ... 30 s
- Emergency stop/ main switch for all-pole disconnection
- Door hinge mounted on the right side
- Door handles: Comfort handles with safety lock
- Parameterizable limits for the protection of the device under test
- Insulation guard monitor
- Insulation guard can be switched off

Note: If the insulation guard is switched off, a separate insulation guard must be available at the test item and is integrated in the emergency chain. The customer is then responsible for the safety of the test bench by himself

- Signal light on the control cabinet with magnetic base
- Red: error; Yellow: Operation, Green: Ready for operation

Intrinsic safety

- Intrinsically safe against overheating, over-load, short circuit and no-load operation
- Protection of polarity protection by checking the polarity before closing the output contactors, no polarity protection on the polarity reversal
- Monitoring of all internal voltages, currents and temperatures DC output contactors, capable of disconnecting at full load current
- Mains-side contactors ensure voltage-free operation
- Discharging of all internal high-voltage sources during emergency stop

Interface to the supervisory system on the terminal block:

- Enable output contactors
- Signal output contact open / closed
- Message of limit value violation
- Message sums error
- Emergency stop message
- Release system
- Emergency stop input

System Options

Extended Voltage Range

SL 1045A-T01 0-6 V operating range

Extend voltage range per channel from 0 to 6 V. (Voltage accuracy: ± 1 mV, type 150 μ V)

Cabinet Base Option Class

SL1042A-701 Base stand

Control cabinet is placed on top of a 15 cm high base stand.
(total height including base stand: 2.38 m)

SL1042A-702 Rollers

Control cabinet stands on top of 25 cm high rollers and can be moved.
(total height including rollers: 2.48 m)

Service Options

Service features depends highly on the facilities, expertise of the customer and overall scope of the project. For that reason, it is not possible to give exact service efforts without knowing the requirements and goals of the customer. Keysight is offering the following services to secure a successful project execution and to reduce the ramp-up time for our customers.

HS0003A-100 Project Management

Project management is highly recommended for each test bench project. By ordering the project management service, an experienced project manager is dedicated to your project and acts as direct communication interface from Keysight to the customers project management team.

The project manager takes over the responsibility:

- To observe internal project progress and secure that project schedule/ project milestones are kept.
- That any unscheduled occasions with relevance for the project are immediately communicated and discussed with the customer.
- To provide complete and accurate project documentation to the customer.

R9001A-201 Installation Service

The scope of the offered installation service strongly depends on the individual facility of the customer. Please share all relevant information and requirements with regards to test bench components that require installation such as connection to the local grid and to the local water supply with your local field engineer that scope of service personnel and material costs for installation can be calculated.

Note: Installation can also be executed by the customer.

R9001A-202 Start-up Assistance Service

The start-up assistance service is offered to guide the customer during first usage of the test bench after installation. Start-up assistance service is highly recommended for each test bench project. It includes:

- Local presence of experienced test bench engineer during first usage of the test bench.
- Consulting of customer personnel with regards to intended usage of the test bench (e.g. initial test with customer specimen)
- Review of executed hardware installation of Keysight products
- Review and consulting to software settings of operation software if ordered travel expanses

Note: Start-up assistance service is offered on a daily base. Keysight recommends to consider at least two days of start-up assistance service for each test bench project.

HS0002A - Productivity Support Service

The productivity support service is offered to support, consult and train the customers operation personnel on the one hand to reduce the ramp-up time for initial usage of a new test bench, on the other hand with regards to any unexpected system behavior during the test bench life cycle. Productivity support service is executed via remote (phone/internet) or on site (on request). It includes:

- Direct access to an experienced system specialist via Phone/Internet.
- Support for failure analysis and trouble shoot
- Software and programming support & consulting

Note: Keysight recommends to consider at least two days of productivity support service for each test bench project.

Learn more at: www.keysight.com

For more information on Keysight Technologies' products, applications or services, please contact your local Keysight office. The complete list is available at: www.keysight.com/find/contactus

