

Agilent Technologies Connector-based Probes

User's Guide



Agilent Technologies

Notices

© Agilent Technologies, Inc. 2000-2004, 2007

No part of this manual may be reproduced in any form or by any means (including electronic storage and retrieval or translation into a foreign language) without prior agreement and written consent from Agilent Technologies, Inc. as governed by United States and international copyright laws.

Manual Part Number

16760-97016, December 2007

Print History

16760-97016, December 2007
16760-97014, November 2004
16760-97012, June 2003
16760-97010, January 2003
16760-97008, September 2002
16760-97007, February 2002
16760-97005, January 2002
16760-97004, May 2001
16760-97002, April 2001
16760-97001, February 2001
16760-97000, December 2000

Agilent Technologies, Inc.
1900 Garden of the Gods Road
Colorado Springs, CO 80907 USA

Trademark Acknowledgements

UNIX is a registered trademark of the Open Group.

Windows and MS Windows are U.S. registered trademarks of Microsoft Corporation.

Windows NT is a U.S. registered trademark of Microsoft Corporation.

Warranty

The material contained in this document is provided “as is,” and is subject to being changed, without notice, in future editions. Further, to the maximum extent permitted by applicable law, Agilent disclaims all warranties, either express or implied, with regard to this manual and any information contained herein, including but not limited to the implied warranties of merchantability and fitness for a particular purpose. Agilent shall not be liable for errors or for incidental or consequential damages in connection with the furnishing, use, or performance of this document or of any information contained herein. Should Agilent and the user have a separate written agreement with warranty terms covering the material in this document that conflict with these terms, the warranty terms in the separate agreement shall control.

Technology Licenses

The hardware and/or software described in this document are furnished under a license and may be used or copied only in accordance with the terms of such license.

Restricted Rights Legend

If software is for use in the performance of a U.S. Government prime contract or subcontract, Software is delivered and licensed as “Commercial computer software” as defined in DFAR 252.227-7014 (June 1995), or as a “commercial item” as defined in FAR 2.101(a) or as “Restricted computer software” as defined in FAR 52.227-19 (June 1987) or any equivalent agency regulation or contract clause. Use, duplication or disclosure of Software is subject to Agilent Technologies’ standard commercial license terms, and non-DOD Departments and Agencies of the U.S. Government will receive no greater than Restricted Rights as defined in FAR 52.227-19(c)(1-2) (June

1987). U.S. Government users will receive no greater than Limited Rights as defined in FAR 52.227-14 (June 1987) or DFAR 252.227-7015 (b)(2) (November 1995), as applicable in any technical data.

Safety Notices

CAUTION

A **CAUTION** notice denotes a hazard. It calls attention to an operating procedure, practice, or the like that, if not correctly performed or adhered to, could result in damage to the product or loss of important data. Do not proceed beyond a **CAUTION** notice until the indicated conditions are fully understood and met.

WARNING

A **WARNING** notice denotes a hazard. It calls attention to an operating procedure, practice, or the like that, if not correctly performed or adhered to, could result in personal injury or death. Do not proceed beyond a **WARNING** notice until the indicated conditions are fully understood and met.

Contents

1 Probing Options

Probing Solutions for Agilent High Speed State Analyzers - At a Glance 8

E5378A 100-pin single-ended probe 8

E5379A 100-pin differential probe 8

E5380A 38-pin single-ended probe 9

Introduction to Probing Options 10

Descriptions of specific probes and adapters 10

Number of probes required 10

Maximum state speed supported 11

The E5378A 100-pin Single-ended Probe 12

The E5379A 100-pin Differential Probe 13

The E5380A 38-pin Single-ended Probe 14

The E5386A Half-channel Adapter 16

2 Mechanical Considerations

E5378A and E5379A 100-pin Single-ended and Differential Probes 20

Characteristics 20

Probe dimensions 20

Samtec connector dimensions 21

Support shroud dimensions 22

Footprint dimensions 23

Pin assignments for the E5378A 100-pin single-ended probe 24

Pin assignments for the E5379A 100-pin differential probe 27

E5380A 38-pin Single-ended Probe	30
Characteristics	30
Probe dimensions	30
MICTOR connector dimensions	31
Support shroud dimensions	31
Footprint dimensions	32
E5380A 38-pin single-ended probe pin out table	34
E5386A Half-channel Adapter (16760A only)	35
Characteristics	35
Adapter dimensions	35
Pinout for the half-channel adapter when connected to E5378A	36
Pinout for the half-channel adapter when connected to E5379A	37

3 Operating the Probes

Equivalent Probe Loads	42
E5378A and E5379A models	42
E5380A model	43
Measured versus modeled input impedance	44
Time Domain Transmission (TDT) E5378A and E5379A	45
Step Inputs E5378A and E5379A	48
Eye Opening E5378A and E5379A	51

4 Circuit Board Design

Transmission Line Considerations	56
Recommended Routing	57
16760A Data and Clock Inputs per Operating Mode	59
Thresholds	61
E5378A 100-pin single-ended probe	61

E5379A 100-pin differential probe	62
E5380A 38-pin single-ended probe	63
Signal Access	64
Labels split across probes	64
Reordered bits	64
Half-channel 1.25 and 1.5 Gb/s modes (16760A only)	65

5 Recommended Reading

For More Information	68
MECL System Design Handbook	68
High-speed Digital Design	68
Designing High-speed Target Systems for Logic Analyzer Probing	68

6 Connectors and Shrouds

Ordering Probing Connectors and Shrouds	70
---	----



1 Probing Options

Probing Solutions for Agilent High Speed State Analyzers - At a Glance	8
Introduction to Probing Options	10
The E5378A 100-pin Single-ended Probe	12
The E5379A 100-pin Differential Probe	13
The E5380A 38-pin Single-ended Probe	14
The E5386A Half-channel Adapter	16

Information to help you select the appropriate probe for your application.



Probing Solutions for Agilent High Speed State Analyzers - At a Glance

The probes in this manual are designed to be used with the Agilent 16753A, 16754A, 16755A, 16756A, and 16760A logic analyzers. They will also work with any future analyzers that use a 90-pin connector on the cable where the probe attaches to the logic analyzer. For more information on Agilent logic analyzers, refer to <http://www.agilent.com/find/logicanalyzer>. For more information on your specific analyzer, refer to the online help in the product.

E5378A 100-pin single-ended probe

Also available as Option 010 on supported Agilent logic analyzers.

- 34 channels
- State speeds up to 1.5 Gb/s (17 channels)
- 250 mV peak-to-peak sensitivity
- 100-pin Samtec connector
- Requires probing connector kit (see page 70)

E5386A half-channel adapter with E5378A (for use with 16760A)

The E5386A adapter maps the 34 signals from the 100-pin Samtec connector to the 16760A when operating in half-channel state mode.

E5379A 100-pin differential probe

Also available as Option 011 on supported Agilent logic analyzers.

- 17 channels
- State speeds up to 1.5 Gb/s (9 channels)
- 200 mV peak-to-peak sensitivity
- 100-pin Samtec connector
- Requires probing connector kit (see page 70)

E5386A half-channel adapter with E5379A (for use with 16760A)

The E5386A adapter maps the 17 differential signals from the 100-pin Samtec connector to the 16760A when operating in half-channel state mode. This configuration provides state speeds up to 1.5 Gb/s on all 17 channels.

E5380A 38-pin single-ended probe

Also available as Option 012 on supported Agilent logic analyzers.

- Compatible with boards designed for Agilent E5346A 38-pin probe
- 34 Channels
- State speeds up to 600 Mb/s
- 300 mV peak-to-peak sensitivity
- 38-pin MICTOR connector
- Requires AMP MICTOR 38 connector and Agilent support shroud (see page 70)

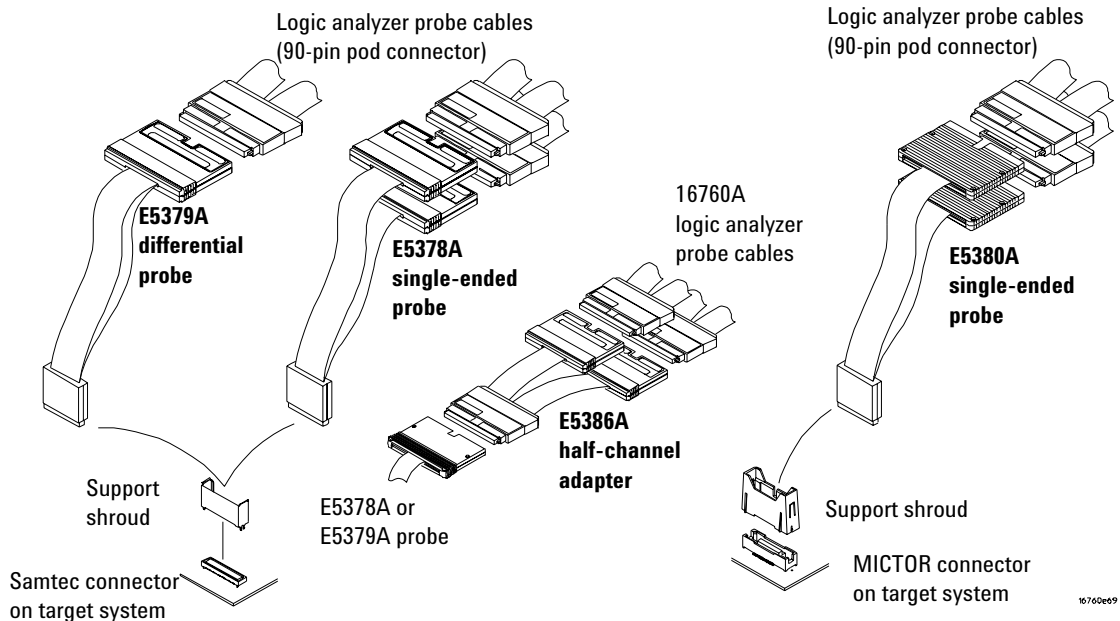

16760e09

Introduction to Probing Options

This chapter provides information to help you select the appropriate probe for your application. You will find descriptions of the logic analyzer probes and adapters. Tables in this chapter show you the number of probes required and the maximum state speed supported depending on which logic analyzer you have. Another table shows the number of data and clock inputs for the various operating modes of your logic analyzer.

Descriptions of specific probes and adapters

- E5378A 100-pin single-ended probe (page 12)
- E5379A 100-pin differential probe (page 13)
- E5380A 38-pin single-ended probe (page 14)
- E5386A Half-channel adapter (page 16)

NOTE

The 100-pin probes (E5378A, E5379A) are recommended over the 38-pin probe (E5380A). The 100-pin probes have much less intrusive loading on the target system, they operate at the 16760A logic analyzers full specified state clock speed of 1.5 Gb/s, and they support smaller-amplitude signals.

Number of probes required

This table shows how many probes are required to provide connections to all channels of your logic analyzer module.

Table 1 Number of probes required

Probe	Logic Analyzer Module	
	16760A	16753A, 16754A, 16755A, 16756A
E5378A 100-pin single-ended probe	1	2
E5379A 100-pin differential probe	2	4
E5380A 38-pin single-ended probe	1	2

Maximum state speed supported

This table gives you the maximum state speed that is supported by the combination of a probe and your logic analyzer module.

Table 2 Maximum state speed supported

Probe	Logic Analyzer Module	
	16760A	16753A, 16754A, 16755A, 16756A
E5378A 100-pin single-ended probe	1.5 Gb/s	600 Mb/s
E5379A 100-pin differential probe	1.5 Gb/s	600 Mb/s
E5380A 38-pin single-ended probe	600 Mb/s	600 Mb/s

The E5378A 100-pin Single-ended Probe

The Agilent E5378A is a 34-channel, single-ended, 100-pin probe compatible with the Agilent 16753A, 16754A, 16755A, 16756A, and 16760A logic analysis modules. It is capable of capturing data up to the rated maximum state (synchronous) analysis clock rates of all the supported analyzers, with signal amplitudes as small as 250 mV peak-to-peak. A 100-pin connector must be installed on the target system board to mate with the E5378A.

The Agilent 16760-68702 or 16760-68703 probing connector kit is required for connecting the E5378A probe to your target system. The kit contains five mating connectors and five support shrouds. The connectors and shrouds may be ordered separately if desired. See the table on page 70 for part numbers.

See Also: Chapter 2 for the mechanical information to design the connector into your target system board.

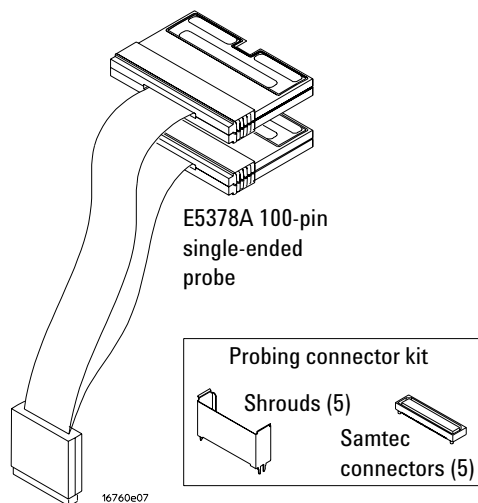

Figure 1 E5378A 100-pin single-ended probe and probing connector kit

The E5379A 100-pin Differential Probe

The Agilent E5379A is a 17-channel, differential, 100-pin probe compatible with the Agilent 16753A, 16754A, 16755A, 16756A, and 16760A logic analysis modules. It is capable of capturing data up to the rated maximum state (synchronous) analysis clock rates of all the supported analyzers, with differential signal amplitudes as small as 200 mV peak-to-peak. A 100-pin connector must be installed on the target system board to mate with the E5379A.

The Agilent 16760-68702 or 16760-68703 probing connector kit is required for connecting the E5379A probe to your target system. The kit contains five mating connectors and five support shrouds. The connectors and shrouds may be ordered separately if desired. See the table on page 70 for part numbers.

Differential Input Amplitude Definition For differential signals, the difference voltage $V - \bar{V}$ must be greater than or equal to 200 mV p-p.

See Also: Chapter 2 for the mechanical information to design the connector into your target system boards.

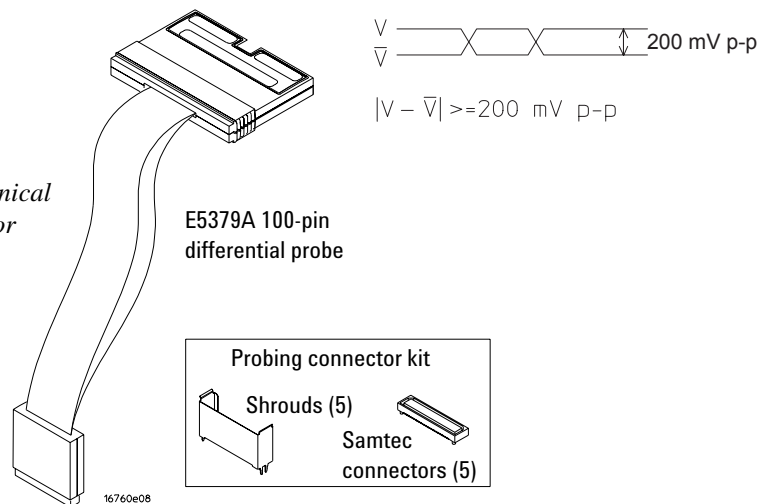

Figure 2 E5379A 100-pin differential probe and probing connector kit

The E5380A 38-pin Single-ended Probe

The E5380A is a 34-channel, single-ended, 38-pin probe designed to be compatible with the AMP MICTOR 38-pin connector. It is pin-compatible with target systems that were designed for the Agilent E5346A 38-pin probe, thus enabling you to use Agilent's latest logic analyzers with target systems that were designed for older Agilent logic analyzers. The E5380A is compatible with the Agilent 16753A, 16754A, 16755A, 16756A, and 16760A logic analysis modules. It is capable of capturing state (synchronous) data at clock speeds up to 600 MHz, at data rates up to 600 Mb/s, with signal amplitudes as small as 300 mV peak-to-peak. The data valid window into the logic analyzer module must be increased by 500 ps when using the E5380A.

The Agilent E5346-68701 or E5346-68700 probing connector kit is required for connecting the E5380A probe to your target system. The kit contains five mating connectors and five support shrouds. The connectors and shrouds may be ordered separately if desired. See the table on page 70 for part numbers.

See Also: Chapter 2 for the mechanical information to design the connector into your target system boards.

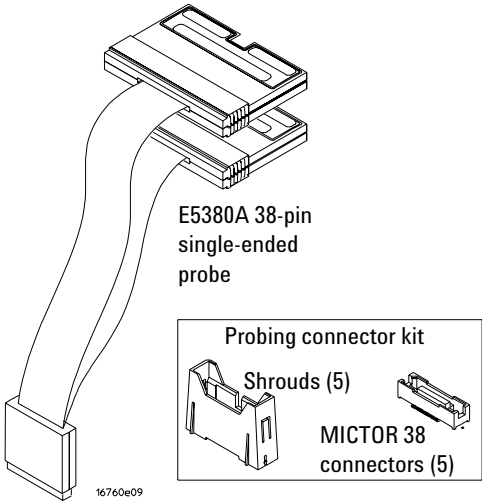
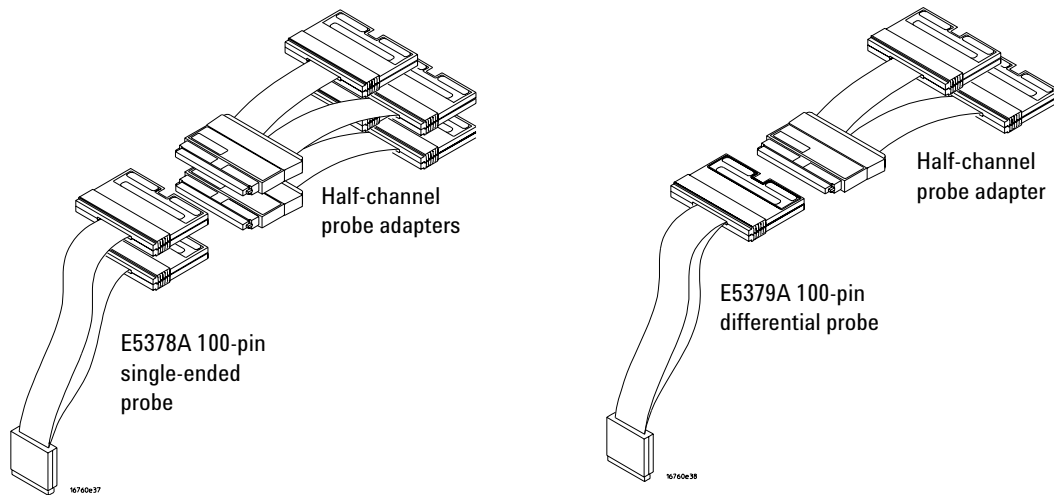

Figure 3 E5380A 38-pin single-ended probe and probing connector kit

The E5386A Half-channel Adapter

The E5386A half-channel adapter is intended to be used with the 16760A logic analyzer in half-channel state mode and works with:

- E5378A 100-pin single-ended probe
- E5379A 100-pin differential probe



The E5386A half-channel adapter has its own ID code. When using the adapter, the logic analyzer recognizes its code rather than that of the probe which is attached to the target. Therefore, the user interface format menu doesn't automatically set thresholds to the proper values. You need to go into the threshold menu and select (differential, custom, or standard settings).

When using the adapter in half-channel state:

- Clock-bits are not available in half-channel state mode (although JCLK on the master is still used).
- Be sure to connect Master pod 1 of the logic analyzer to the upper bits, 8-15 + clk, on the half-channel adapter. This is necessary to connect the clock in the system under test to the logic analyzer system clock.

- Using the E5386A does not reduce the performance of the 16760A and the E5378A or E5379A system.

If the E5386A is used in full-channel state mode, the thresholds on the unused (odd) bits are floating. This could result in spurious activity indicators in the format menu.

1 Probing Options



2 Mechanical Considerations

E5378A and E5379A 100-pin Single-ended and Differential Probes 20

E5380A 38-pin Single-ended Probe 30

E5386A Half-channel Adapter (16760A only) 35

Once you have decided which probe is required, use the following mechanical information to design the appropriate connector into your target system board.



E5378A and E5379A 100-pin Single-ended and Differential Probes

Characteristics

Electrical considerations such as equivalent probe loads, input impedance, and time domain transmission are shown in chapters 3 and 4 of this manual. Other characteristics are dependant on the logic analyzer module you are using.

Probe dimensions

The following figures show the dimensions of the 100-pin single-ended and differential probes.

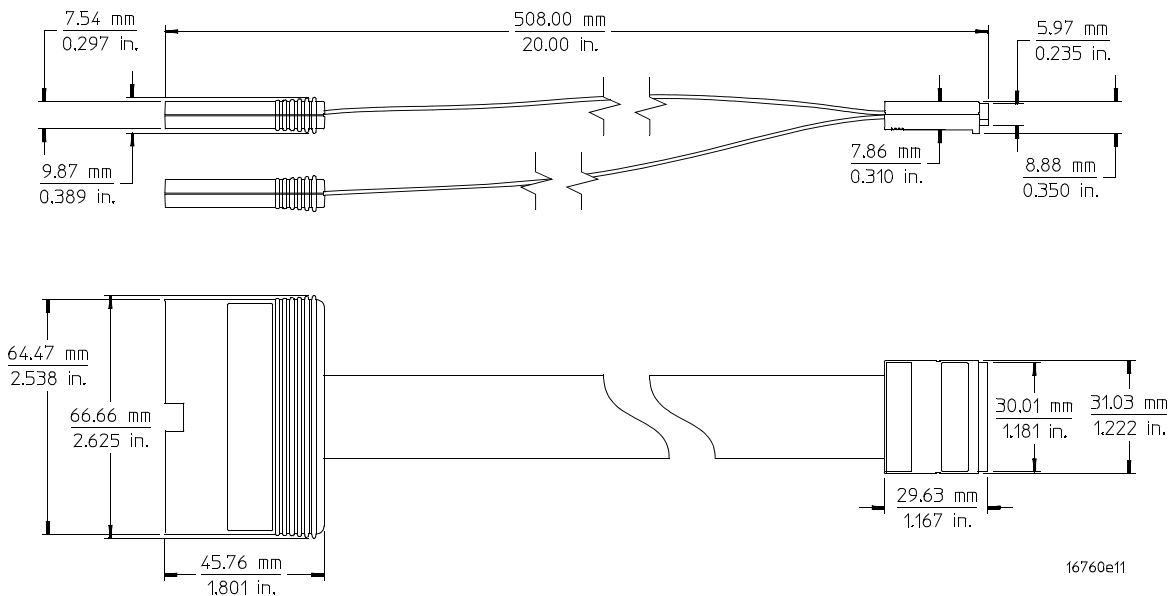

Figure 4 E5378A 100-pin single-ended probe dimensions

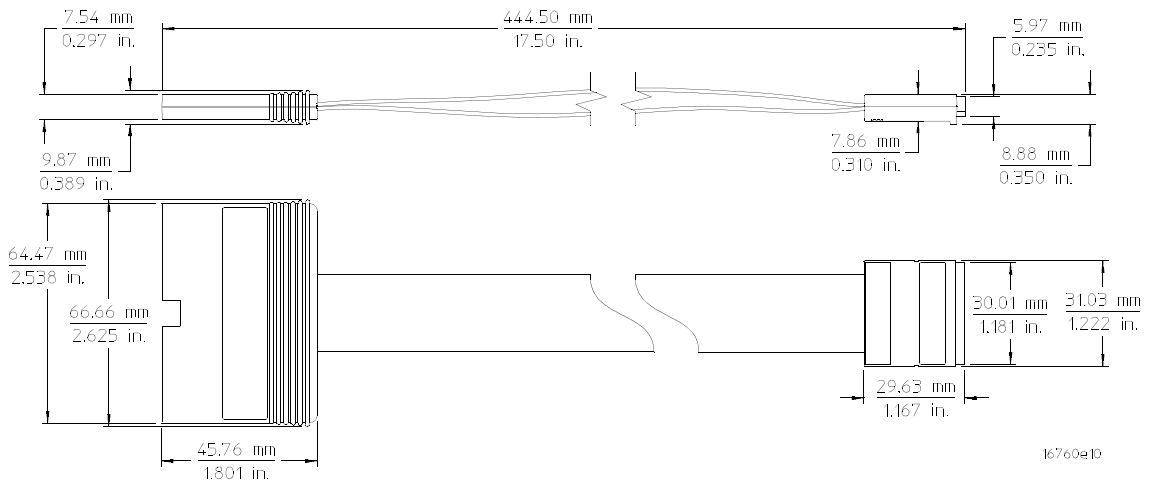

Figure 5 E5379A 100-pin differential probe dimensions

Samtec connector dimensions

The E5378A and E5379A probes require a probe kit that contains 100-pin Samtec connectors. Refer to page 70 for the kit part numbers.

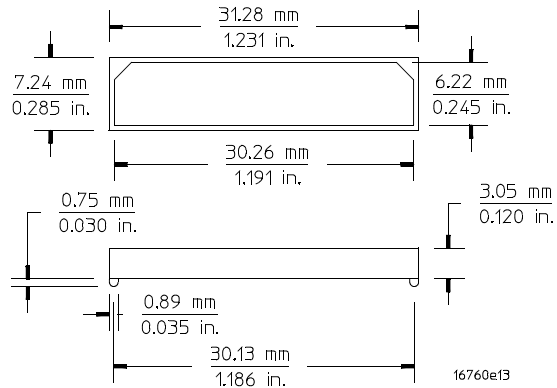

Figure 6 Samtec 100-pin connector dimensions

Support shroud dimensions

Support shrouds are not required but are recommended if pulling forces may be applied to the cables that could cause the connector to be dislodged. Refer to page 70 for the kit part numbers.

CAUTION

The support shrouds are made of conductive metal. Care should be taken to avoid shorting adjacent boards or components with the shrouds. For this reason, it may be advisable not to connect the shrouds to ground.

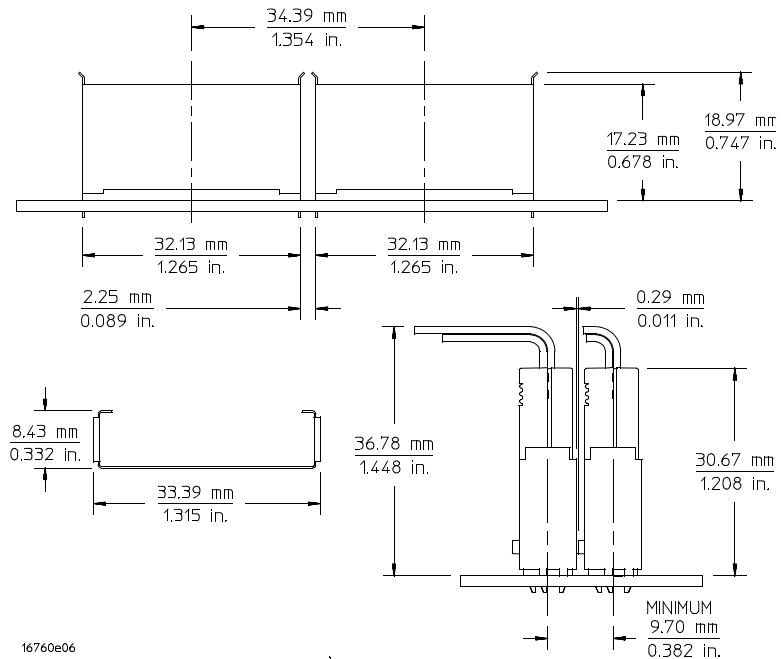

Figure 7 100-pin Samtec support shroud dimensions

Footprint dimensions

Use the following 100-pin Samtec connector footprint and support shroud mounting hole dimensions to design your target system board.

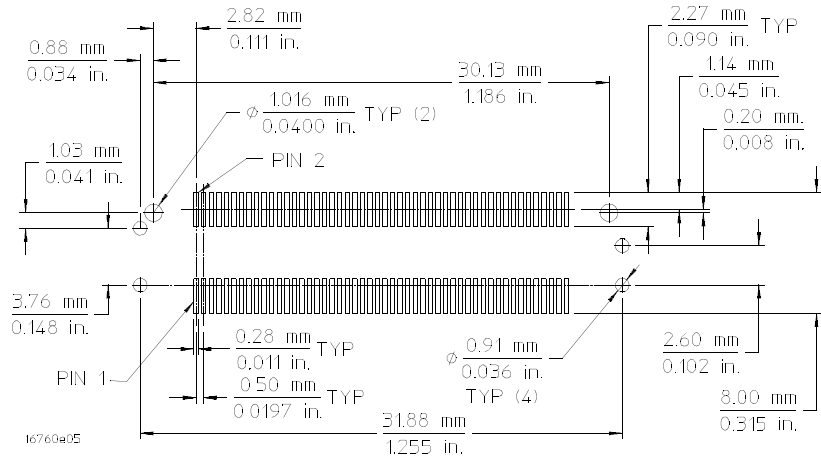

Figure 8 100-pin Samtec connector footprint and support shroud mounting hole dimensions

Pin assignments for the E5378A 100-pin single-ended probe

E5378A Single-ended Probe		Logic Analyzer		E5378A Single-ended Probe		Logic Analyzer	
Signal Name	Pin #	Channel	Pod	Signal Name	Pin #	Channel	Pod
Ground	1			Ground	2		
Do Not Connect	3			Do Not Connect	4		
Ground	5			Ground	6		
D0	7	→ 0	Whichever pod is connected to "Odd" on the E5378A probe	D0	8	→ 0	Whichever pod is connected to "Even" on the E5378A probe
Ground	9			Ground	10		
D1	11	→ 1		D1	12	→ 1	
Ground	13			Ground	14		
D2	15	→ 2		D2	16	→ 2	
Ground	17			Ground	18		
D3	19	→ 3		D3	20	→ 3	
Ground	21			Ground	22		
D4	23	→ 4		D4	24	→ 4	
Ground	25			Ground	26		
D5	27	→ 5		D5	28	→ 5	
Ground	29		Ground	30			
D6	31	→ 6	D6	32	→ 6		
Ground	33		Ground	34			
D7	35	→ 7	D7	36	→ 7		
Ground	37		Ground	38			
D8	39	→ 8	D8	40	→ 8		
Ground	41		Ground	42			
D9	43	→ 9	D9	44	→ 9		
Ground	45		Ground	46			
D10	47	→ 10	D10	48	→ 10		
Ground	49		Ground	50			
D11	51	→ 11	D11	52	→ 11		
Ground	53		Ground	54			

E5378A Single-ended Probe		Logic Analyzer		
Signal Name	Pin #		Channel	Pod
D12	55	→	12	Whichever pod is connected to "Odd" on the E5378A probe
Ground	57			
D13	59	→	13	
Ground	61			
D14	63	→	14	
Ground	65			
D15	67	→	15	
Ground	69			
NC	71			
Ground	73			
NC	75			
Ground	77			
D16p/CLKp	79	→	CLK p	
Ground	81			
D16n/CLKn	83	→	CLK n	
Ground	85			
Ext Ref	87			
Ground	89			
NC	91			
Ground	93			
Ground	95			
Do not connect	97			
Do not connect	99			

E5378A Single-ended Probe		Logic Analyzer		
Signal Name	Pin #		Channel	Pod
D12	56	→	12	Whichever pod is connected to "Even" on the E5378A probe
Ground	58			
D13	60	→	13	
Ground	62			
D14	64	→	14	
Ground	66			
D15	68	→	15	
Ground	70			
NC	72			
Ground	74			
NC	76			
Ground	78			
D16p/CLKp	80	→	CLK p	
Ground	82			
D16n/CLKn	84	→	CLK n	
Ground	86			
Ext Ref	88			
Ground	90			
NC	92			
Ground	94			
Ground	96			
Do not connect	98			
Do not connect	100			

Ground pins indicated in this table are grounded in the probe. Grounding of specific ground pins on the target board is optional. However, the following guidelines should be observed:

- 1 Multiple ground returns are desirable to maintain signal integrity. As many probe ground pins as possible should be connected to ground in the target system board.
- 2 The ground pins located between signal pins are particularly important because they provide improved signal-to-signal isolation. This is particularly important for differential inputs. Excessive coupling between differential inputs causes the apparent input capacitance to increase. Capacitance between the two sides of a differential signal will appear to each side as approximately twice the capacitance to ground, because the capacitance is connected to a signal of opposite polarity. The best practice is to ground as many of these pins on the target board as possible.

Pin assignments for the E5379A 100-pin differential probe

E5379A Differential Probe					
Negative Signals		Positive Signals		Logic Analyzer	
Signal Name	Pin#	Signal Name	Pin#	Channel	Pod
Ground	1	Ground	2		Whichever pod is plugged into the E5379A probe
Do Not Connect	3	Do Not Connect	4		
Ground	5	Ground	6		
D0N	7	D0 p	8	→ 0	
Ground	9	Ground	10		
D1 n	11	D1 p	12	→ 1	
Ground	13	Ground	14		
D2 n	15	D2 p	16	→ 2	
Ground	17	Ground	18		
D3 n	19	D3 p	20	→ 3	
Ground	21	Ground	22		
D4 n	23	D4 p	24	→ 4	
Ground	25	Ground	26		
D5 n	27	D5 p	28	→ 5	
Ground	29	Ground	30		
D6 n	31	D6 p	32	→ 6	
Ground	33	Ground	34		
D7 n	35	D7 p	36	→ 7	
Ground	37	Ground	38		
D8 n	39	D8 p	40	→ 8	
Ground	41	Ground	42		
D9 n	43	D9 p	44	→ 9	
Ground	45	Ground	46		
D10 n	47	D10 p	48	→ 10	
Ground	49	Ground	50		
D11 n	51	D11 p	52	→ 11	
Ground	53	Ground	54		
D12 n	55	D12 p	56	→ 12	

2 Mechanical Considerations

E5379A Differential Probe				Logic Analyzer	
Negative Signals		Positive Signals		Channel	Pod
Signal Name	Pin#	Signal Name	Pin#		
Ground	57	Ground	58		Whichever pod is plugged into the E5379A probe
D13 n	59	D13 p	60	→ 13	
Ground	61	Ground	62		
D14 n	63	D14 p	64	→ 14	
Ground	65	Ground	66		
D15 n	67	D15 p	68	→ 15	
Ground	69	Ground	70		
NC	71	NC	72		
Ground	73	Ground	74		
NC	75	NC	76		
Ground	77	Ground	78		
D16/Clk n	79	D16/Clk p	80	→ Clk	
Ground	81	Ground	82		
NC	83	NC	84		
Ground	85	Ground	86		
NC	87	Ground	88		
N/C	89	N/C	90		
NC	91	NC	92		
Ground	93	Ground	94		
Ground	95	Ground	96		
Do not connect	97	Do not connect	98		
Do not connect	99	Do not connect	100		

Ground pins indicated in this table are grounded in the probe. Grounding of specific ground pins on the target board is optional. However, the following guidelines should be observed:

- 1 Multiple ground returns are desirable to maintain signal integrity. As many probe ground pins as possible should be connected to ground in the target system board.
- 2 The ground pins located between signal pins are particularly important because they provide improved signal-to-signal isolation. This is particularly important for differential inputs. Excessive coupling between differential inputs causes the apparent input capacitance to increase. Capacitance between the two sides of a differential signal will appear to each side as approximately twice the capacitance to ground, because the capacitance is connected to a signal of opposite polarity. The best practice is to ground as many of these pins on the target board as possible.

E5380A 38-pin Single-ended Probe

Characteristics

Electrical considerations such as equivalent probe loads, input impedance, and time domain transmission are shown in chapters 3 and 4 of this manual. Other characteristics are dependant on the logic analyzer module you are using.

Probe dimensions

The following figure shows the dimensions of the 38-pin single-ended probe.

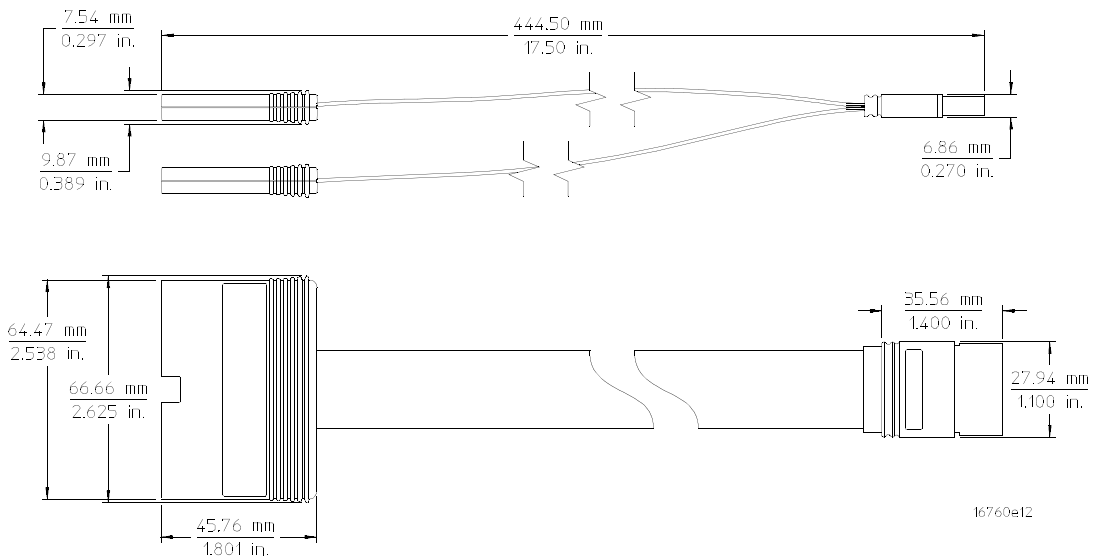

Figure 9 E5380A 38-pin single-ended probe dimensions

MICTOR connector dimensions

The E5380A probe is compatible with target systems designed for the Agilent E5346A 38-pin probe. This probe requires a probe kit that contains MICTOR connectors and shrouds. Refer to page 70 for the kit part numbers.

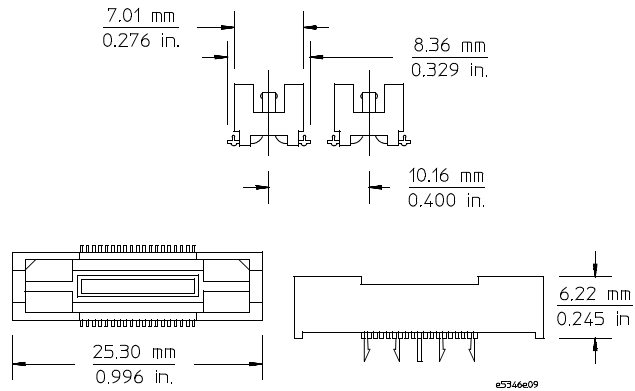

Figure 10 MICTOR 38-pin connector dimensions

Support shroud dimensions

Support shrouds are not required but are recommended if pulling forces may be applied to the cables that could cause the connector to be dislodged. Refer to page 70 for the kit part numbers.

2 Mechanical Considerations

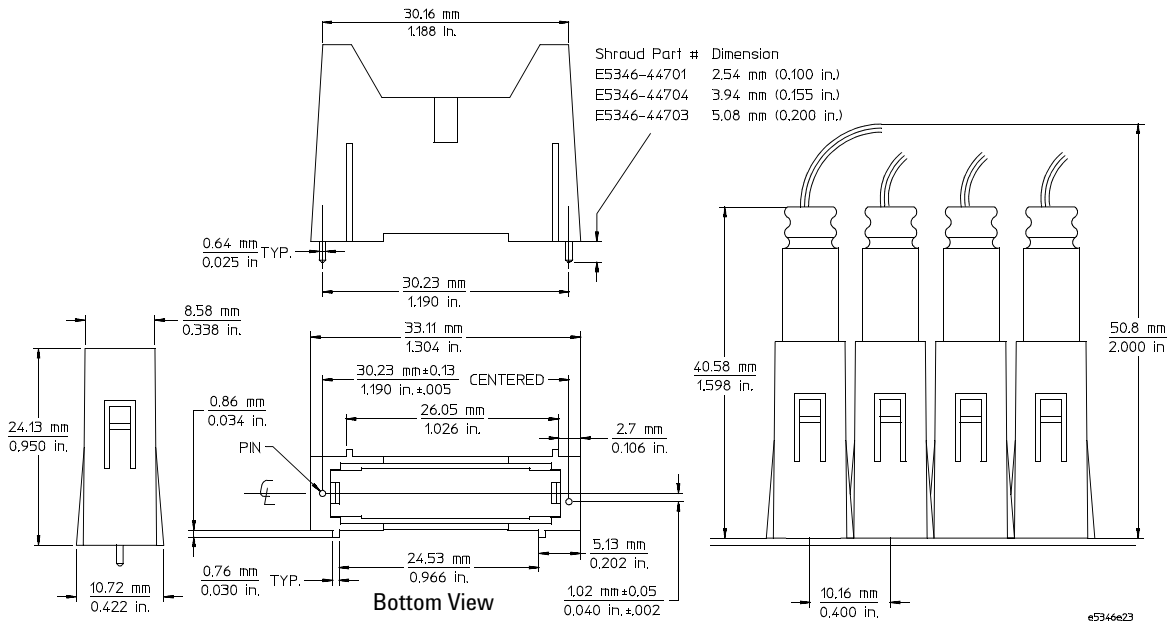

Figure 11 Support shroud dimensions for the MICTOR 38-pin connector

Footprint dimensions

Use the following 38-pin MICTOR connector footprint and support shroud mounting hole dimensions to design your target system board.

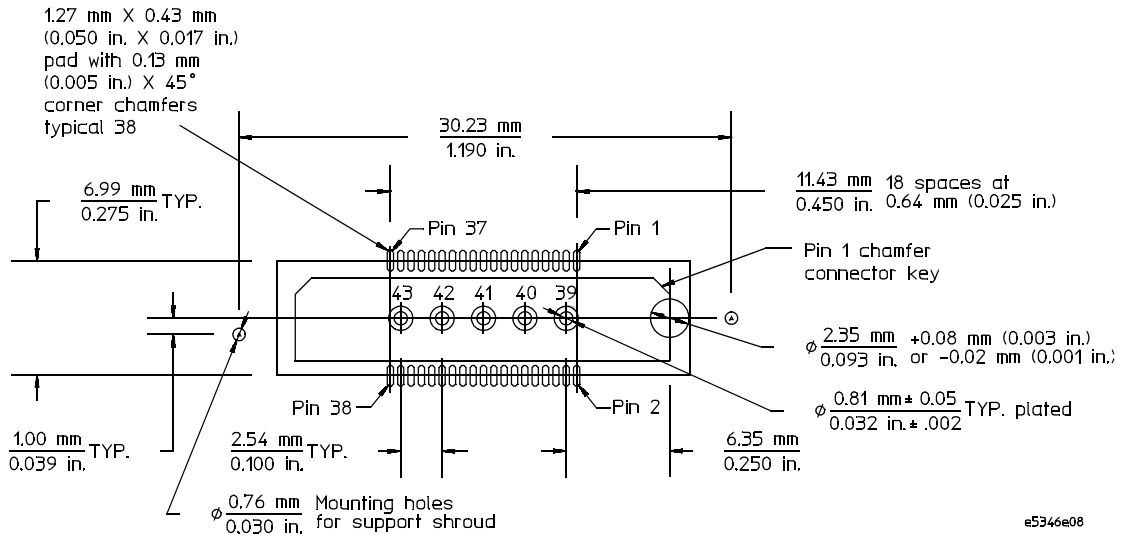

Figure 12 38-pin MICTOR connector footprint and support shroud mounting hole dimensions.

E5380A 38-pin single-ended probe pin out table

E5380A Single-ended Probe		Logic Analyzer		
Signal Name	MICTOR Pin #	Channel	Pod	
Clk	5	→ Clk	Whichever pod is connected to "Even" on the E5380A probe	
D15	7	→ 15		
D14	9	→ 14		
D13	11	→ 13		
D12	13	→ 12		
D11	15	→ 11		
D10	17	→ 10		
D9	19	→ 9		
D8	21	→ 8		
D7	23	→ 7		
D6	25	→ 6		
D5	27	→ 5		
D4	29	→ 4		
D3	31	→ 3		
D2	33	→ 2		
D1	35	→ 1		
D0	37	→ 1		
Ground	39-43			

E5380A Single-ended Probe		Logic Analyzer		
Signal Name	MICTOR Pin #	Channel	Pod	
Clk	6	→ Clk	Whichever pod is connected to "Odd" on the E5380A probe	
D15	8	→ 15		
D14	10	→ 14		
D13	12	→ 13		
D12	14	→ 12		
D11	16	→ 11		
D10	18	→ 10		
D9	20	→ 9		
D8	22	→ 8		
D7	24	→ 7		
D6	26	→ 6		
D5	28	→ 5		
D4	30	→ 4		
D3	32	→ 3		
D2	34	→ 2		
D1	36	→ 1		
D0	38	→ 1		
Ground	39-43			

Do not connect the following pins. These pins are +5 volt supply and DC return for analysis probes.

+5 V dc	1
Ground	3

Do not connect the following pins. They are used by the Agilent logic analyzer with an emulator or analysis probe to program or read target information.

SCL	2
SDA	4

Do not connect the following pins. These pins are +5 volt supply and DC return for analysis probes.

+5 V dc	1
Ground	3

Do not connect the following pins. They are used by the Agilent logic analyzer with an emulator or analysis probe to program or read target information.

SCL	2
SDA	4

E5386A Half-channel Adapter (16760A only)

Characteristics

The E5386A half-channel adapter works with the 16760A logic analyzer and the E5378A 100-pin Single-ended Probe or the E5379A 100-pin Differential Probe. Electrical considerations such as equivalent probe loads, input impedance, and time domain transmission are shown in chapters 3 and 4 of this manual. Other characteristics are dependant on the logic 16760A module.

Adapter dimensions

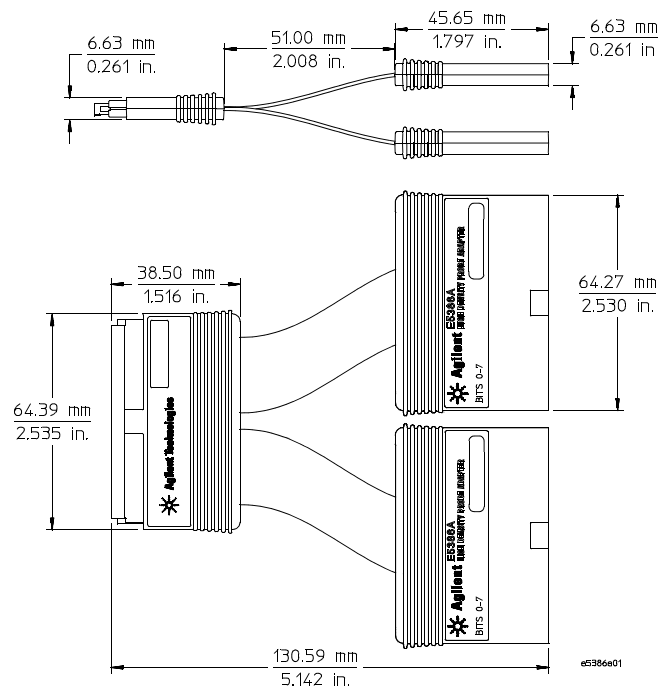

Figure 13 Half-channel adapter dimensions.

Pinout for the half-channel adapter when connected to E5378A

When used with the E5378A 100-pin single-ended probe, you need two half-channel adapters, one adapter for Odd data and one for Even data. The table below shows the pin assignments.

The E5386A that is connected to the end of the E5378A labeled 'odd' becomes the 'odd' E5386A adapter.

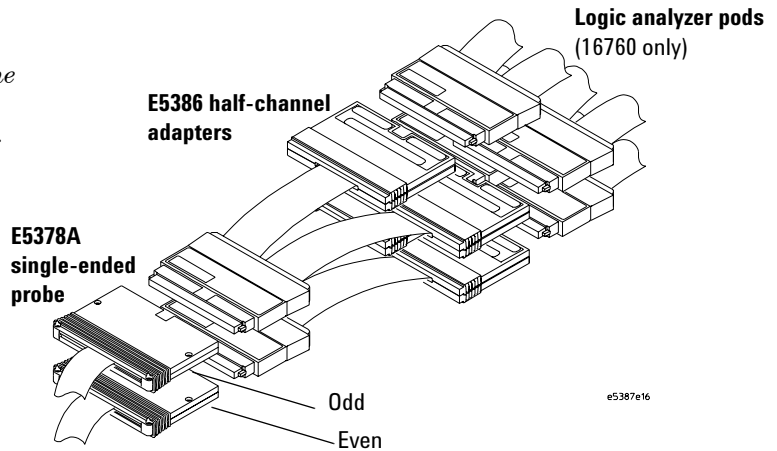

Figure 14 Two half-channel adapters with E5378A

Table 3 Pin-out table for two E5386A half-channel adapters connected to an E5378A

E5386A Adapter Odd					E5386A Adapter Even				
E5378A Single-ended Probe		Logic Analyzer			E5378A Single-ended Probe		Logic Analyzer		
Signal Name	Pin #	Channel	Pod		Signal Name	Pin #	Channel	Pod	
D0	7	→ 0	Whichever pod is connected to bits 0-7 on the odd E5386A		D0	8	→ 0	Whichever pod is connected to bits 0-7 on the even E5386A	
D1	11	→ 2			D1	12	→ 2		
D2	15	→ 4			D2	16	→ 4		
D3	19	→ 6			D3	20	→ 6		
D4	23	→ 8			D4	24	→ 8		
D5	27	→ 10			D5	28	→ 10		
D6	31	→ 12			D6	32	→ 12		
D7	35	→ 14			D7	36	→ 14		
D8	39	→ 0	Whichever pod is connected to bits 8-15 on the odd E5386A		D8	40	→ 0	Whichever pod is connected to bits 8-15 on the even E5386A	
D9	43	→ 2			D9	44	→ 2		
D10	47	→ 4			D10	48	→ 4		
D11	51	→ 6			D11	52	→ 6		
D12	55	→ 8			D12	56	→ 8		
D13	59	→ 10			D13	60	→ 10		
D14	63	→ 12			D14	64	→ 12		
D15	67	→ 14			D15	68	→ 14		
D16 p/Clk p	79	→ Clk p		D16 p/Clk p	80	→ Clk p			
D16 n/Clk p	83	→ Clk n		D16 n/Clk n	84	→ Clk n			
Ext Ref	87	→ Ext Ref		Ext Ref	88	→ Ext Ref			

Pinout for the half-channel adapter when connected to E5379A

When used with the E5379A 100-pin differential probe, you need only one half-channel adapter. The table below shows the pin assignments.

2 Mechanical Considerations

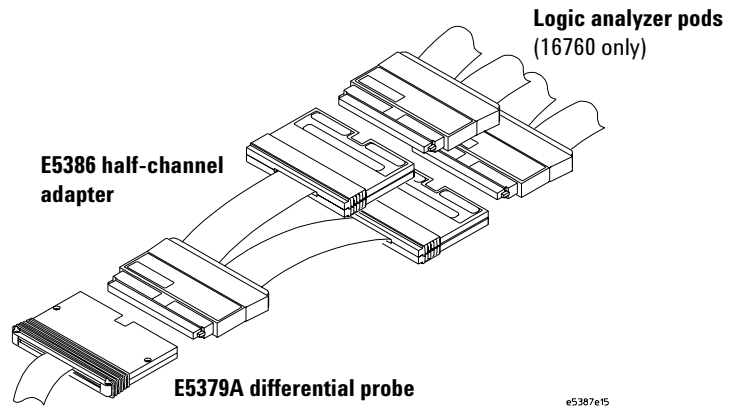

Figure 15 One half-channel adapter when connected to E5379A

Table 4 Pin-out table for one E5386A half-channel adapter connected to an E5379A

E5379A Differential Probe				Logic Analyzer	
<u>Negative Signals</u>		<u>Positive Signals</u>		Channel	Pod
Signal Name	Pin#	Signal Name	Pin#		
D0 n	7	D0 p	8	→ 0	Whichever pod is plugged into bits 0-7 ↓
D1 n	11	D1 p	12	→ 2	
D2 n	15	D2 p	16	→ 4	
D3 n	19	D3 p	20	→ 6	
D4 n	23	D4 p	24	→ 8	
D5 n	27	D5 p	28	→ 10	
D6 n	31	D6 p	32	→ 12	
D7 n	35	D7 p	36	→ 14	

E5379A Differential Probe					
Negative Signals		Positive Signals		Logic Analyzer	
Signal Name	Pin#	Signal Name	Pin#	Channel	Pod
D8 n	39	D8 p	40	→ 0	Whichever pod is plugged into bits 8-15 ↓
D9 n	43	D9 p	44	→ 2	
D10 n	47	D10 p	48	→ 4	
D011 n	51	D11 p	52	→ 6	
D12 n	55	D12 p	56	→ 8	
D13 n	59	D13 p	60	→ 10	
D14 n	63	D14 p	64	→ 12	
D15 n	67	D15 p	68	→ 14	
D16 n/Clk n	79	D16 p/Clk p	80	→ Clk	

2 Mechanical Considerations



3 Operating the Probes

Equivalent Probe Loads	42
Time Domain Transmission (TDT) E5378A and E5379A	45
Step Inputs E5378A and E5379A	48
Eye Opening E5378A and E5379A	51

Electrical considerations such as equivalent probe loads, input impedance, time domain transmission (TDT), step inputs, and eye opening.



Equivalent Probe Loads

The equivalent probe loads for the E5378A, E5379A, and E5380A probes are shown in the figures below. The equivalent loads include the 100-pin Samtec or 38-pin MICTOR connector.

E5378A and E5379A models

The following simple model is accurate up to 1 GHz. Transient analysis with Spice is fastest with this model.

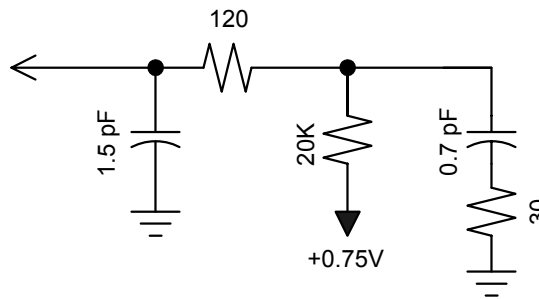

Figure 16 Simple probe load model

The following transmission line model is the most accurate. It is accurate up to 5 GHz. Transient analysis with Spice will be the slowest with this model.

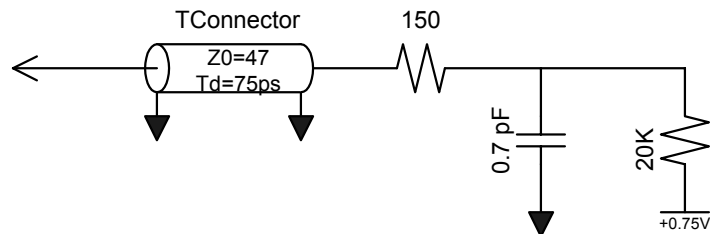

Figure 17 Transmission line model

The following lumped LC transmission line model is identical to the transmission line, but provides faster transient analysis.

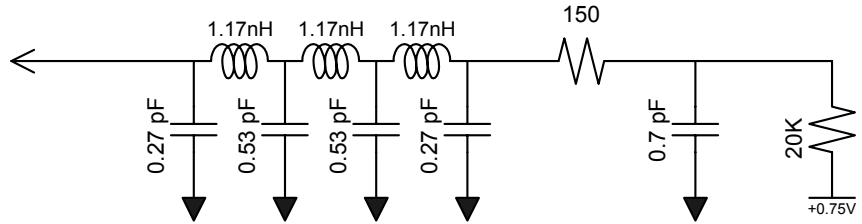

Figure 18 Lumped LC model

E5380A model

The following equivalent probe load for the E5380A includes the target connector. The model is accurate up to 1 GHz.

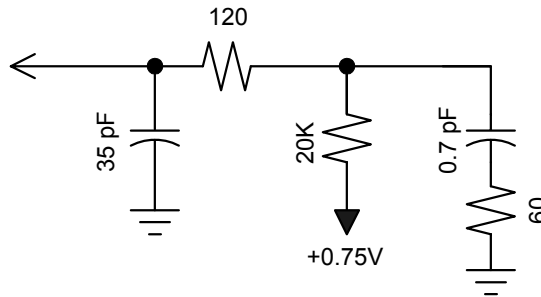
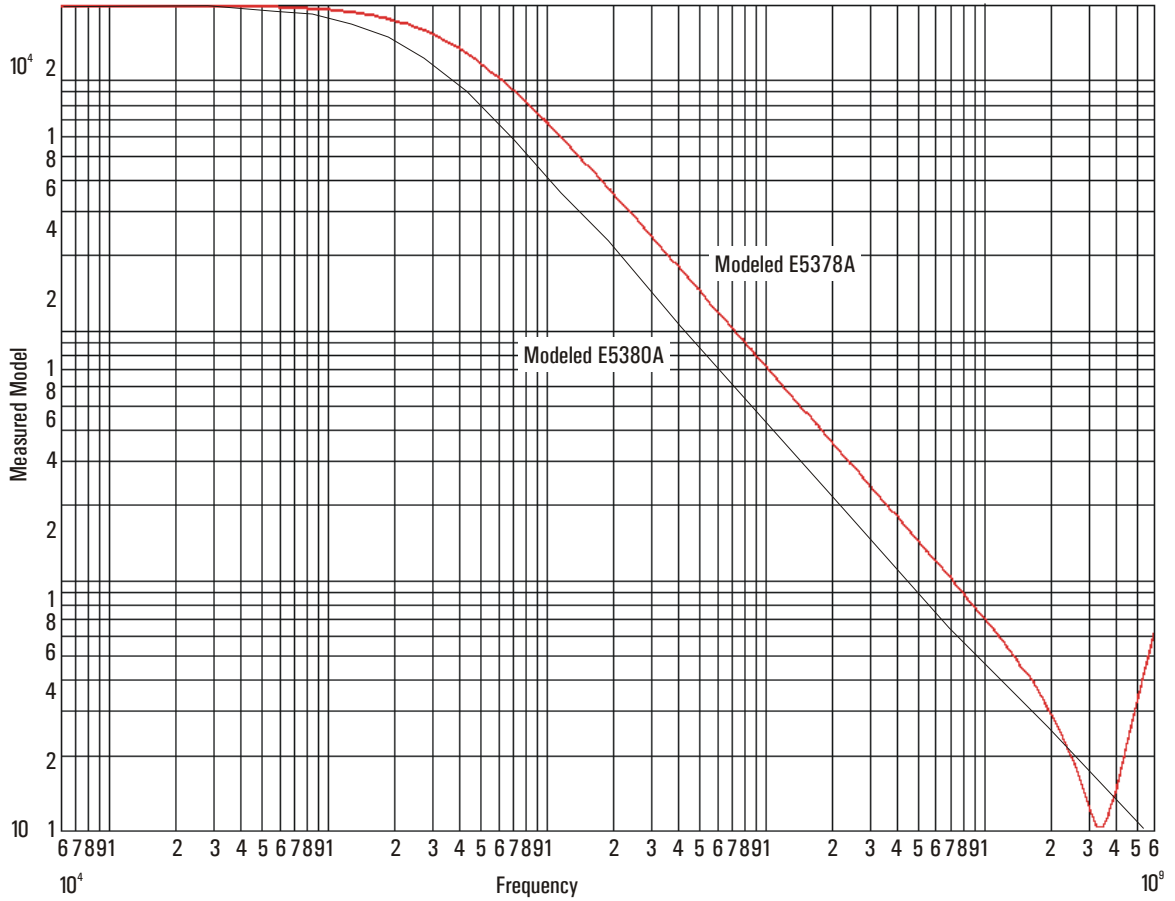

Figure 19 Equivalent load for E5380A

Measured versus modeled input impedance



Time Domain Transmission (TDT) E5378A and E5379A

All probes have a loading effect on the circuit when they come in contact with the circuit. Time domain transmission (TDT) measurements are useful for understanding the probe loading effects as seen at the target receiver. The following TDT measurements were made mid-bus on a 50Ω transmission line load terminated at the receiver. These measurements show how the E5378A/E5379A probes affect an ideal step seen by the receiver for various rise times.

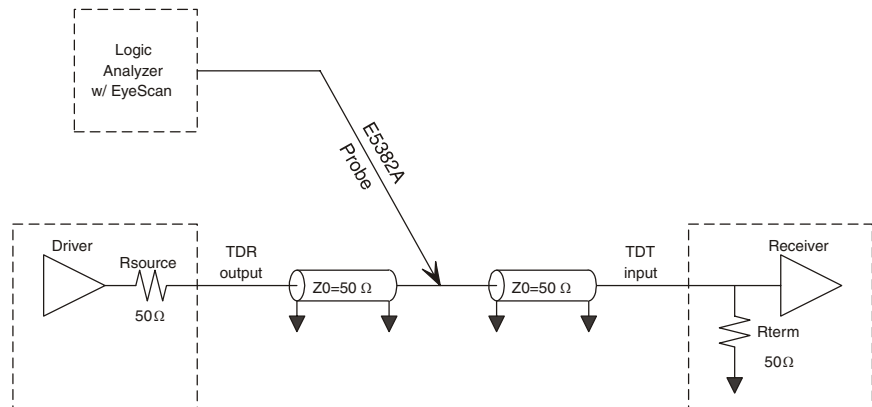

Figure 20 TDT measurement schematic

The following plots were made on an Agilent 54750A oscilloscope using TDT.

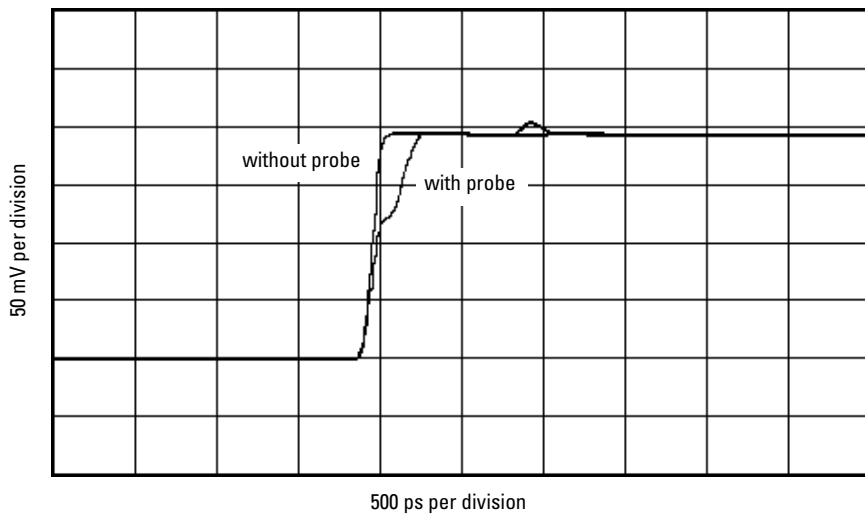

Figure 21 TDT measurement at receiver with and without probe load for 100 ps rise time

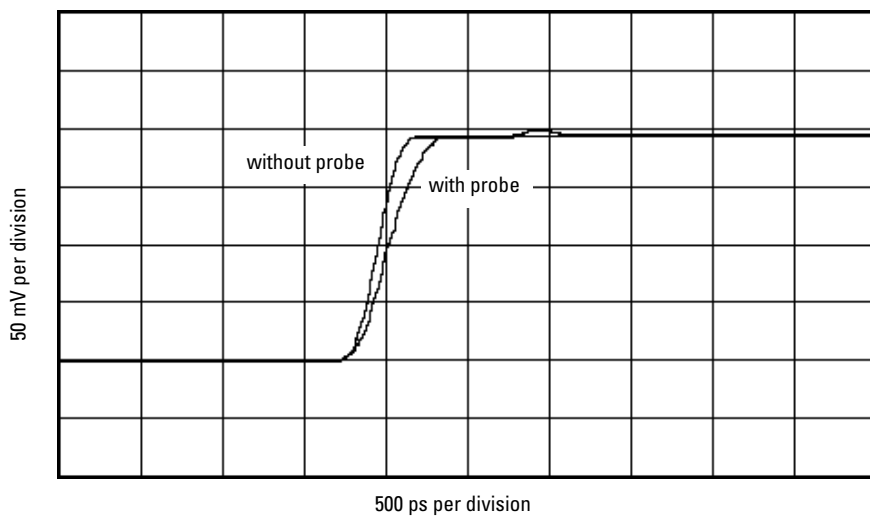

Figure 22 TDT measurement at receiver with and without probe load for 250 ps rise time

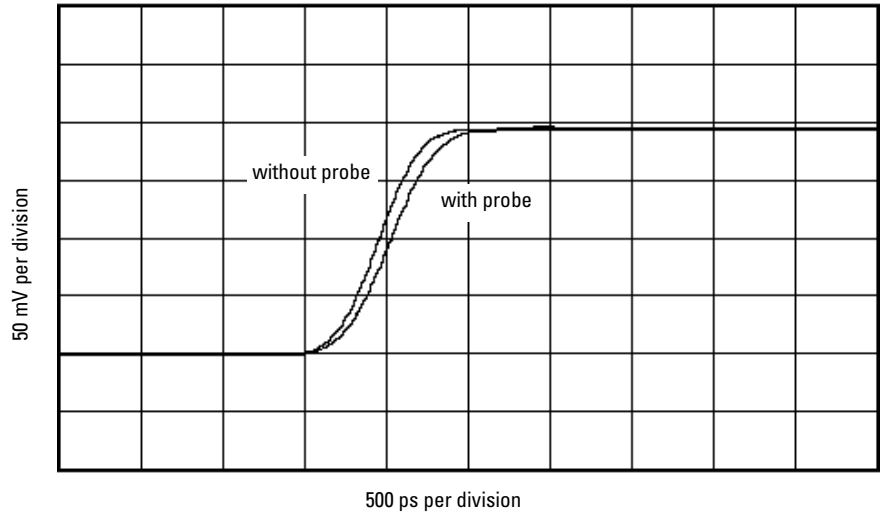

Figure 23 TDT measurement at receiver with and without probe load for 500 ps rise time

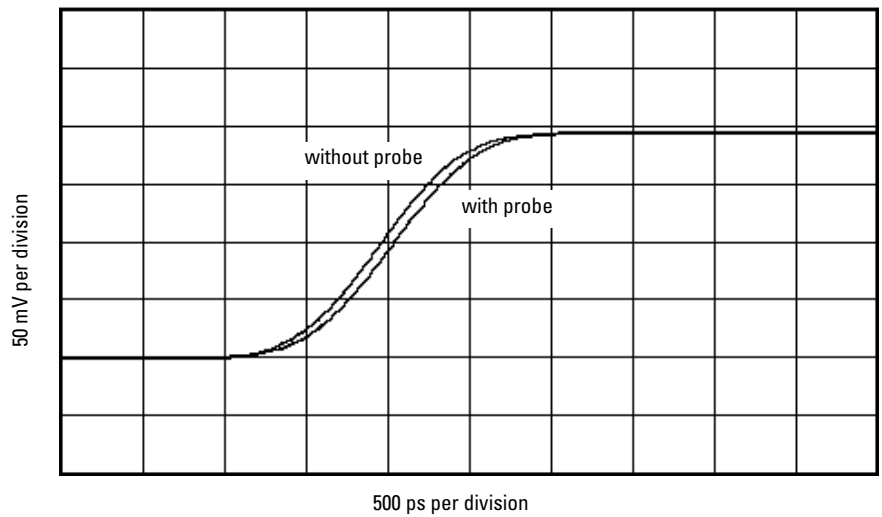

Figure 24 TDT measurement at receiver with and without probe load for 1 ns rise time

Step Inputs E5378A and E5379A

Maintaining signal fidelity to the logic analyzer is critical if the analyzer is to accurately capture data. One measure of a system's signal fidelity is to compare V_{in} to V_{out} for various step inputs. For the following graphs, V_{in} is the signal at the logic analyzer probe tip. Eye Scan was used to measure V_{out} , the signal seen by the logic analyzer. The measurements were made on a mid-bus connection to a 50Ω transmission line load terminated at the receiver. These measurements show the logic analyzer's response while using the E5378/79 probes.

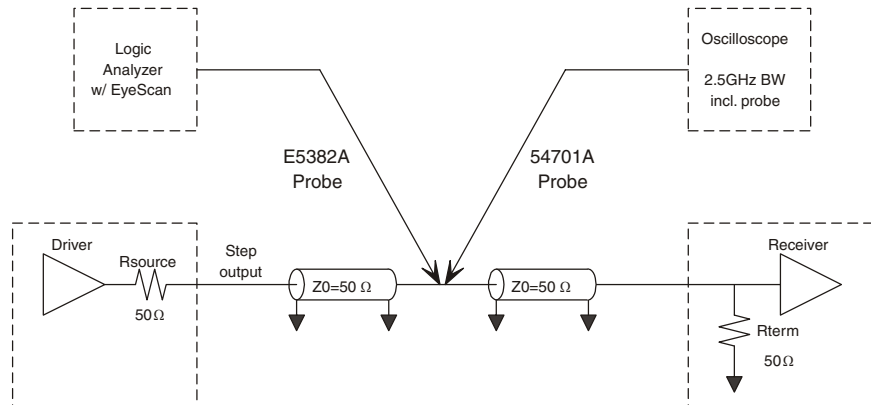

Figure 25 Step input measurement schematic

The following plots were made on an Agilent 16760A logic analyzer using an Agilent 8133A pulse generator with various rise time converters.

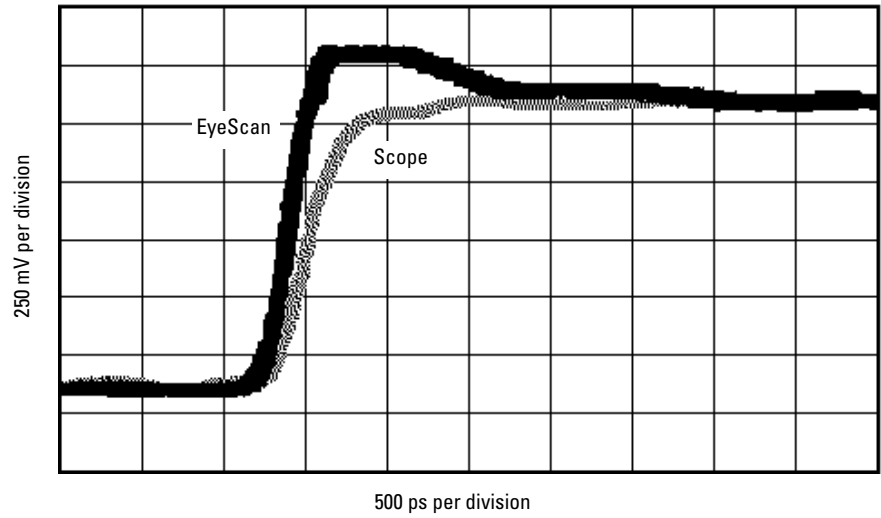

Figure 26 Logic analyzer's response to 250 ps rise time

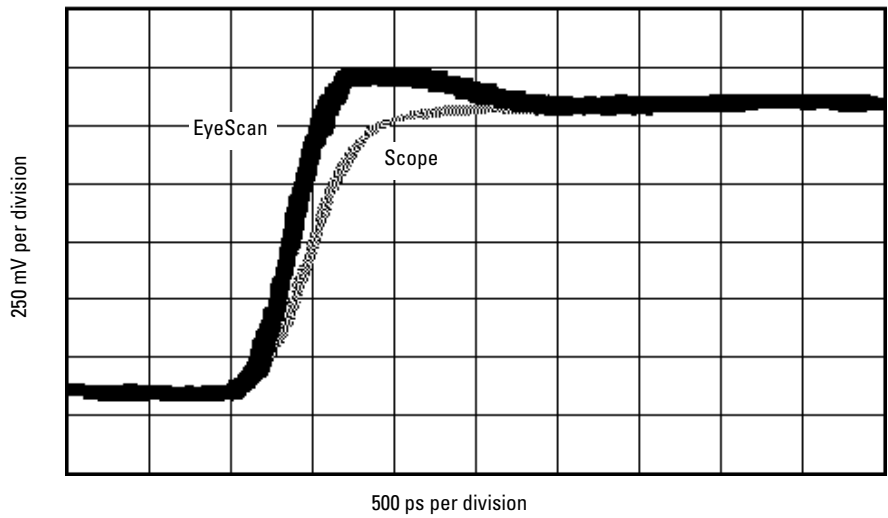

Figure 27 Logic analyzer's response to 500 ps rise time

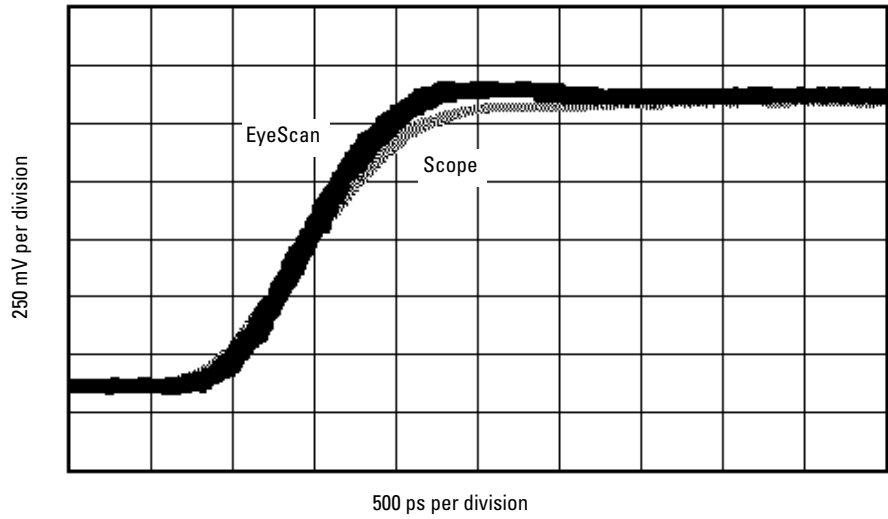

Figure 28 Logic analyzer's response to 1 ns rise time

Eye Opening E5378A and E5379A

The eye opening at the logic analyzer is the truest measure of an analyzer's ability to accurately capture data. Seeing the eye opening at the logic analyzer is possible with Eye Scan. The eye opening viewed with Eye Scan helps the user know how much margin the logic analyzer has, where to sample and at what threshold. Any probe response that exhibits overshoot, ringing, probe non-flatness, noise, and other issues all deteriorate the eye opening seen by the logic analyzer. The following eye diagrams were measured using Eye Scan while probed mid-bus on a 50Ω transmission line load terminated at the receiver. The data patterns were generated using a $2^{23}-1$ pseudo random bit sequence (PRBS).

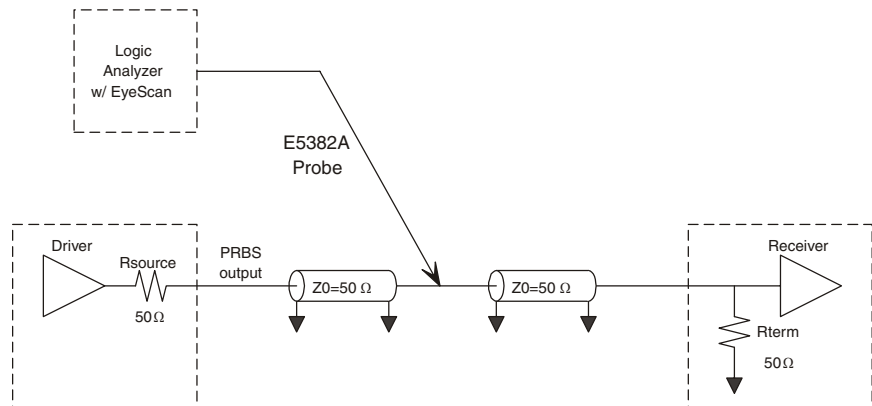

Figure 29 Eye opening measurement schematic

The following plots were made on an Agilent 16760A logic analyzer using an Agilent 8133A pulse generator with a 250 ps rise time converter. The following measurements use Eye Scan to show the margin at 800, 1250, and 1500MT/s.

3 Operating the Probes

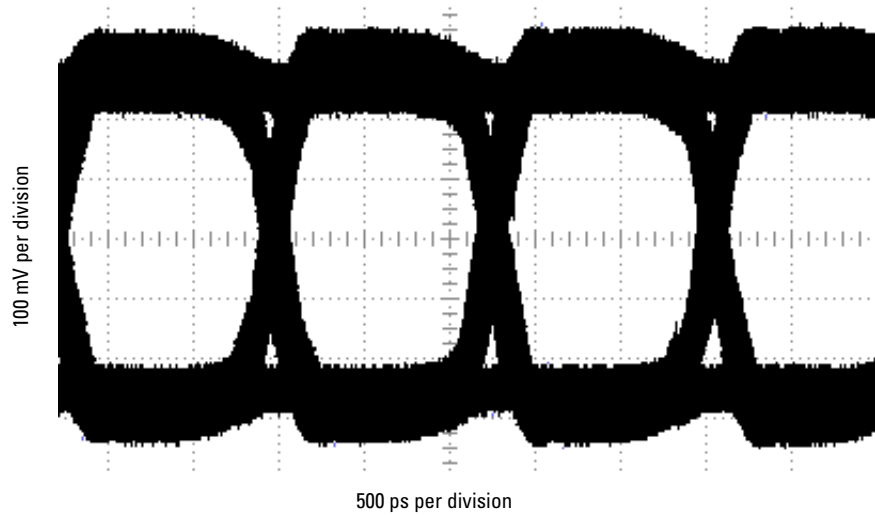

Figure 30 Logic analyzer eye opening for a PRBS signal of 500 mV p-p, 800 Mb/s data rate

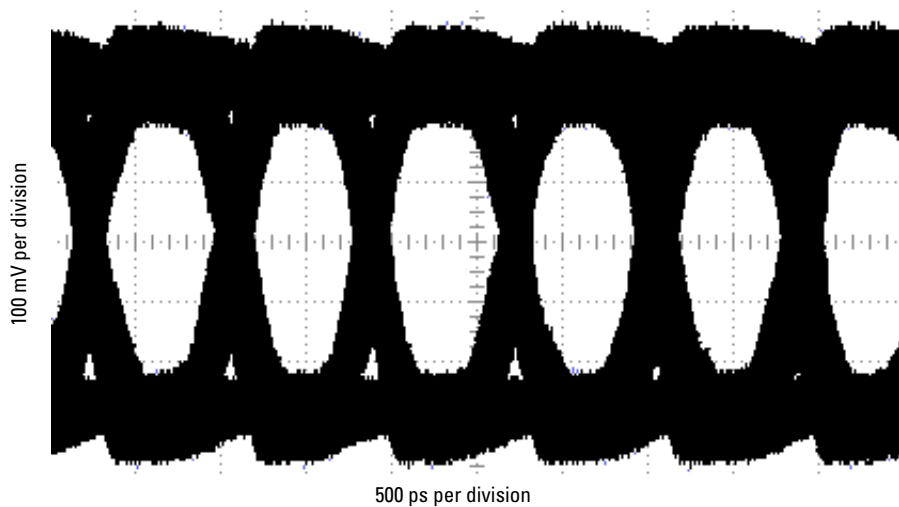

Figure 31 Logic analyzer eye opening for a PRBS signal of 500 mV p-p, 1250 Mb/s data rate

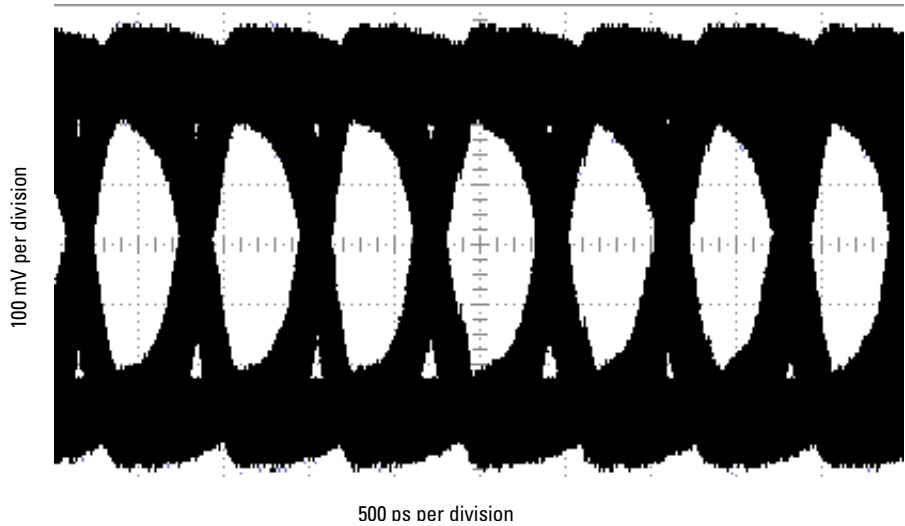

Figure 32 Logic analyzer eye opening for a PRBS signal of 500 mV p-p, 1500 Mb/s data rate

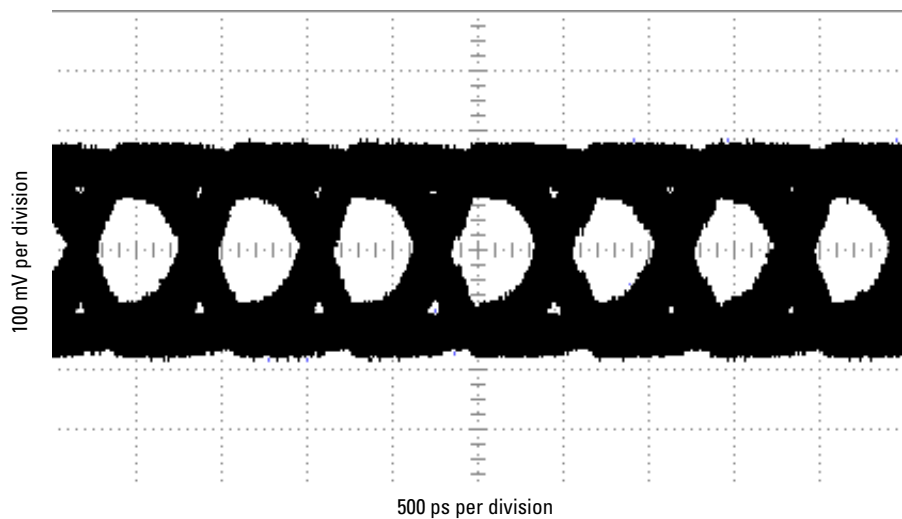

Figure 33 Logic analyzer eye opening for a PRBS signal of 200 mV p-p, 1500 Mb/s data rate

3 Operating the Probes



4 Circuit Board Design

Transmission Line Considerations	56
Recommended Routing	57
16760A Data and Clock Inputs per Operating Mode	59
Thresholds	61
Signal Access	64
Half-channel 1.25 and 1.5 Gb/s modes (16760A only)	65

Design considerations when you layout your circuit board.



Transmission Line Considerations

Stubs connecting signal transmission lines to the connector should be as short as feasible. Longer stubs will cause more loading and reflections on a transmission line. If the electrical length of a stub is less than 1/5 of the signal rise time, it can be modeled as a lumped capacitance. Longer stubs must be treated as transmission lines.

Example

Assume you are using FR-4 PC board material with a dielectric constant of ~4.3 for inner-layer traces (microstrip). For example, A 0.28 cm long stub in an inner layer has a propagation delay of ~20 ps. Therefore, for a signal with a rise time of 100 ps or greater, a 0.28 cm stub will behave like a capacitor.

The trace capacitance per unit length will depend on the trace width and the spacing to ground or power planes. If the trace is laid out to have a characteristic impedance of 50 ohms, it turns out that the capacitance per unit length is ~ 1.2 pF/cm. Therefore, the 0.28 cm stub in the previous example would have an effective capacitance equal to ~0.34 pF.

This trace capacitance is in addition to the probe load model.

Recommended Routing

The probe load models provided in the previous chapter do not include the vias and short stubs shown in this drawing. The additional load on the target due to this rating is very topology dependant. You need to consider these effects in addition to the published probe load.

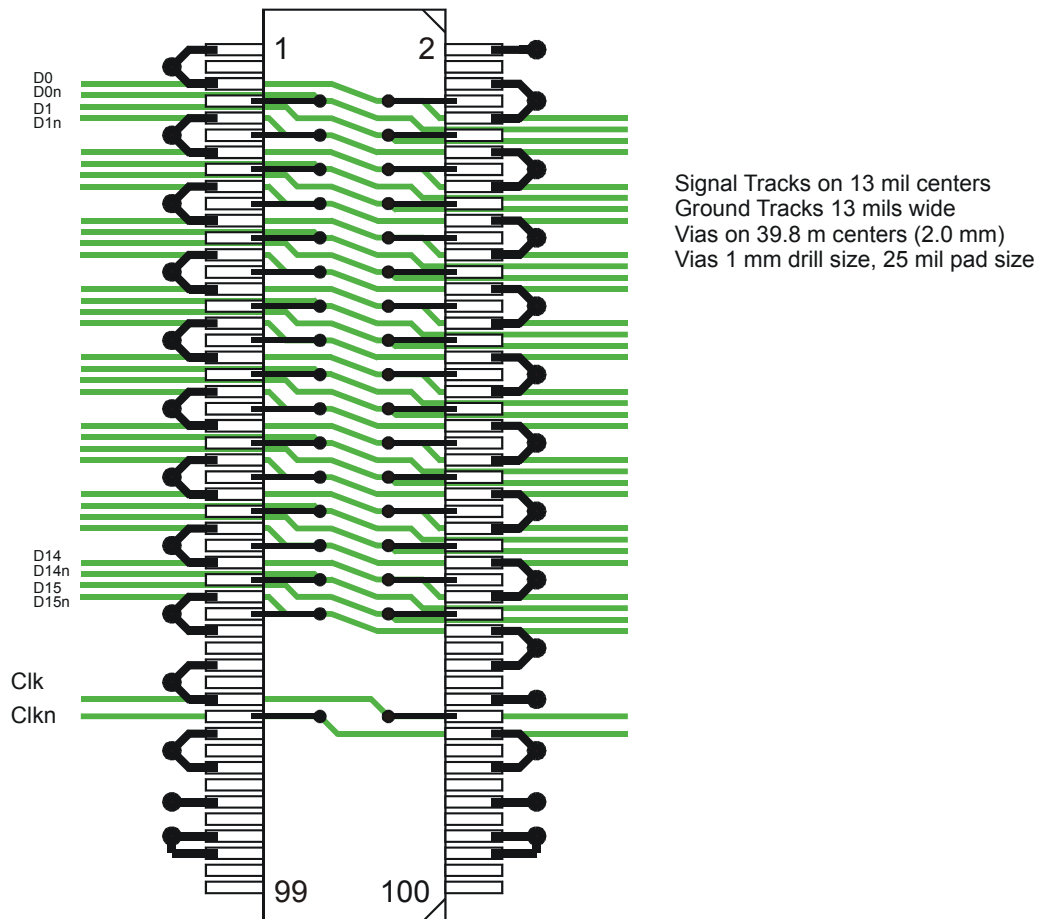

Figure 34 16-bit differential flow-through routing

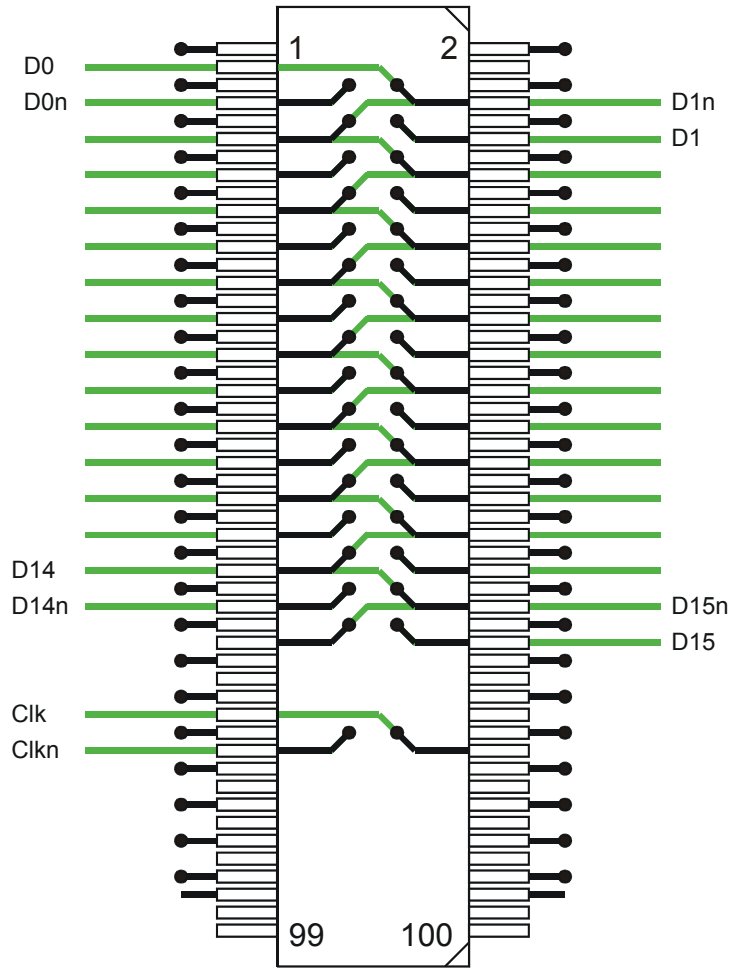

Figure 35 16-bit differential signal pairs broken out to alternate sides

16760A Data and Clock Inputs per Operating Mode

The following table shows the number of data and clock inputs for each connector on your target system for the various operating modes of your 16760A logic analyzer.

Table 5 Data clock inputs per operating mode

16760A Operating Mode	E5378A	E5378A with half-channel adapter E5386A	E5379A	E5379A with half-channel adapter E5386A	E5380A
Synchronous (state) analysis 200 Mb/s, 400 Mb/s, 800 Mb/s	32 data plus 2 clock inputs (see note 1)	N/A	16 data plus 1 clock input (see note 1)	N/A	32 data plus 2 clock inputs (see note 1)
Synchronous (state) analysis 1250 Mb/s 1500 Mb/s	16 data plus 1 clock input (see note 2)	32 data plus 2 clock inputs (see note 2)	8 data plus 1 clock input (see note 2)	16 data plus 2 clock inputs (see note 2)	N/A
Eye scan mode 800 Mb/s	32 data plus 2 clock inputs (see note 1)	N/A	16 data plus 1 clock input (see note 1)	N/A	32 data plus 2 clock inputs (see note 1)
Eye scan mode 1500 Mb/s	16 data plus 1 clock input (see note 2)	32 data plus 2 clock inputs (see note 2)	8 data plus 1 clock input (see note 2)	16 data plus 2 clock inputs (see note 2)	N/A
Timing mode	32 data plus 2 clock inputs (see note 3)	N/A	16 data plus 1 clock input (see note 3)	N/A	32 data plus 2 clock inputs (see note 3)

Note 1: In the 200 Mb/s, 400 Mb/s, and 800 Mb/s synchronous (state) analysis modes, and the 800 Mb/s eye scan mode, there is one clock input which must be routed

to the clock input on pod 1 (of the master module, in a multi-card set). The clock inputs on other pods can be assigned to labels and acquired as data inputs.

Note 2: In the 1250 Mb/s and 1500 Mb/s synchronous (state) analysis modes, and in the 1500 Mb/s eye scan mode, the clock inputs on other pods cannot be assigned to labels and acquired as data inputs.

Note 3: In asynchronous (timing) analysis, all inputs including clocks can be acquired and assigned to labels.

- To realize 17 data inputs (in full-channel mode) while using time tags in addition to a clock input on a single 16760A module or on the master module in a multi-card set, you must route the data signals to pod 2 and the clock to pod 1. A convenient way to avoid laying out a second connector to connect only the clock signal is to use the Agilent E5382A flying-lead set to make the connection to the clock.
- To use the qualifier input for eye scan, the qualifier signal must be routed to the clock input on pad 2 (K clock), and the clock must be routed to the clock input on pod 1 (J clock), each on the master module in case of a multi-card set.
- In a multiple-card set, the clock used for synchronous (state) analysis must be routed to the clock input on pod 1 of the master module. On a single card, the clock must be routed to the clock input on pod 1.

Thresholds

E5378A 100-pin single-ended probe

Data inputs

The E5378A 100-pin single-ended probe has two inputs for a user-supplied threshold voltage for the data inputs, one for the even pod and one for the odd pod. The threshold inputs (pins 87 and 88) may be grounded, left open, or connected to a dc power supply. For each group of data inputs, you may either:

- Supply a threshold voltage between -3V dc and +5V dc to the threshold input. The logic analyzer will use this threshold to determine when the signal is high or low.

Or

- Adjust the logic threshold in the user interface to between -3V dc and +5V dc.

The advantages of supplying a threshold voltage via the threshold input on the probe are:

- A threshold supplied from the source will typically track changes in supply voltage, temperature, etc.
- A threshold supplied from the target is typically the same threshold that the target system's logic uses to evaluate the signals. Therefore the data captured by the logic analyzer will be congruent with the data as interpreted by the target system.

Clock input

The clock input to the E5378A probe is differential. If you supply a differential clock, you should select the "differential" option in the clock threshold user interface.

If your system uses a single-ended clock signal, the $\overline{\text{clock}}$ input should be either grounded or connected to a dc power supply. You may:

- Ground the $\overline{\text{clock}}$ input and adjust the clock threshold from the user interface to between -3V dc and +5V dc.

Or

- Supply a threshold reference voltage between -3V dc and +5V dc to the $\overline{\text{clock}}$ input. In this case, the clock threshold in the user interface should be set to zero.

If your circuit uses a resistive divider to provide a threshold reference, be sure to consider the equivalent circuit consisting of the 20k Ω resistor connected to +0.75V as shown on page 42 and 43.

The threshold for the clock input has a separate adjustment in the user interface, independent of the data inputs.

E5379A 100-pin differential probe

Data inputs

If you are using the E5379A 100-pin differential probe to acquire differential signals, you would normally allow the logic analyzer to discriminate between high and low states based on the crossover of the data and $\overline{\text{data}}$ inputs.

You may also use the E5379A 100-pin differential probe to acquire single-ended signals. If you are using the E5379A probe to acquire single-ended signals, you should either ground the $\overline{\text{data}}$ inputs or connect them to a dc power supply. You may:

- Ground the $\overline{\text{data}}$ inputs and adjust the threshold in the user interface.

Or

- Supply a threshold reference voltage to the $\overline{\text{data}}$ inputs. In this case, the threshold in the user interface should be set to zero.

If your circuit uses a resistive divider to provide a threshold reference, be sure to consider the equivalent circuit consisting of the 20k Ω resistor connected to +0.75V as shown on page 42 and 43.

Clock input

The same choices exist for the clock input on the E5379A 100-pin differential probe as outlined above for the data inputs. The clock input has a separate, independent threshold adjustment.

E5380A 38-pin single-ended probe

All inputs on the E5380A 38-pin probe are single-ended. The E5380A probe does not have a threshold reference input. When you use the E5380A, you adjust the logic threshold in the user interface.

The clock input on the E5380A is single-ended. The clock threshold may be adjusted independent of the data.

Signal Access

Labels split across probes

If a label is split across more than one pod, this leads to restrictions in triggering. Refer to "Triggering with the Agilent 16760A" (Agilent publication number 5988-2994EN) for more details.

Reordered bits

If bits need to be reordered within a label, this leads to additional restrictions in triggering. Specifically, equalities can be used to evaluate the value of a label with reordered bits, but inequalities cannot be used. You may be able to avoid the need to reorder bits in a label by routing signals to appropriate pins on the probe connector. Refer to "Triggering with the Agilent 16760A" (Agilent publication number 5988-2994EN) for more details.

Half-channel 1.25 and 1.5 Gb/s modes (16760A only)

In the half-channel 1.5 Gb/s mode, the 16760A analyzer accesses only the even channels (0,2,4, etc.). Note that in the 1.5 Gb/s half-channel mode, the clock inputs cannot be assigned as bits in a label.

The E5386A can be used with the E5378A 100-pin Single-ended Probe or the E5379A 100-pin Differential Probe to map the signals from the 100-pin Samtec connector to the 16760A when operating in half-channel state mode.

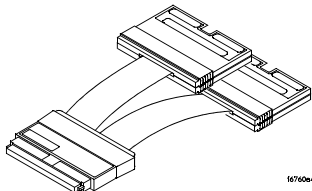

Figure 36 E5386A half-channel adapter



5 Recommended Reading

For More Information [68](#)

A list of recommended reading for more information about systems and high-speed digital design.



For More Information

For more information on Agilent logic analyzers, refer to <http://www.agilent.com/find/logicanalyzer>. For more information on your specific analyzer, refer to the online help in the product.

MECL System Design Handbook

Blood, William R. Jr., "MECL System Design Handbook," 4th edition, 1988, published by Motorola. This handbook can be obtained from ON Semiconductor on the web. Go to <<http://onsemi.com>>. Click on "On-line ordering" under "Documentation." Click on the link "General search." Type in "HB205" in the "Document number" field. Click "Submit." To view the document online, click on "PDF" in the right-hand column titled "PDF MFAX." Or order a hardcopy of the handbook on-line.

High-speed Digital Design

Johnson, Howard W., and Martin Graham, "High-speed Digital Design," Prentice-Hall, 1993, ISBN 0-13-395724-1

Designing High-speed Target Systems for Logic Analyzer Probing

"Designing High-speed Target Systems for Logic Analyzer Probing" Agilent Technologies application note publication number 5988-2989EN.



6 Connectors and Shrouds

Ordering Probing Connectors and Shrouds 70

A table of part numbers for ordering connectors, shrouds, and kits.



Ordering Probing Connectors and Shrouds

Connectors and shrouds may be ordered in kits or ordered separately. Select a support shroud appropriate for the thickness of your PC board. The following table lists the Agilent part numbers for each.

CAUTION

The support shrouds marked with an asterisk in the following table are made of conductive metal. Care should be taken to avoid shorting adjacent boards or components with the shrouds. For this reason it may be advisable not to connect the shrouds to ground.

For Probe Model #	Agilent Part Number	Consists of	For Target PC Board Thickness
E5378A & E5379A	16760-68702	5 Mating Connectors & 5 Support Shrouds*	up to 1.57 mm (0.062 in.)
	16760-68703		up to 3.05 mm (0.120 in.)
	1253-3620 (or Samtec #ASP-65067-01)	1 100-pin Mating Connector	n/a
	16760-02302	1 Support Shroud*	up to 1.57 mm (0.062 in.)
	16760-02303	1 Support Shroud*	up to 3.05 mm (0.120 in.)
E5380A	E5346-68701	5 MICTOR Connectors & 5 Support Shrouds	up to 1.57 mm (0.062 in.)
	E5346-68700	5 MICTOR Connectors & 5 Support Shrouds	1.575 to 3.175 mm (0.062 to 0.125 in.)
	1252-7431	1 MICTOR Connector	n/a
	AMP part #2-767004-2	1 MICTOR Connector	n/a
	E5346-44701	1 Support Shroud	up to 1.57 mm (0.062")
	E5346-44704	1 Support Shroud	1.575 to 3.175 mm (0.062 to 0.125 in.)
	E5346-44703	1 Support Shroud	3.175 to 4.318 mm (0.125 to 0.70 in.)

Safety Notices

This apparatus has been designed and tested in accordance with IEC Publication 1010, Safety Requirements for Measuring Apparatus, and has been supplied in a safe condition. This is a Safety Class I instrument (provided with terminal for protective earthing). Before applying power, verify that the correct safety precautions are taken (see the following warnings). In addition, note the external markings on the instrument that are described under "Safety Symbols."

Warnings

- Before turning on the instrument, you must connect the protective earth terminal of the instrument to the protective conductor of the (mains) power cord. The mains plug shall only be inserted in a socket outlet provided with a protective earth contact. You must not negate the protective action by using an extension cord (power cable) without a protective conductor (grounding). Grounding one conductor of a two-conductor outlet is not sufficient protection.
- Only fuses with the required rated current, voltage, and specified type (normal blow, time delay, etc.) should be used. Do not use repaired fuses or short-circuited fuse holders. To do so could cause a shock or fire hazard.
- If you energize this instrument by an auto transformer (for voltage reduction or mains isolation), the common terminal must be connected to the earth terminal of the power source.
- Whenever it is likely that the ground protection is impaired, you must make the instrument inoperative and secure it against any unintended operation.
- Service instructions are for trained service personnel. To avoid dangerous electric shock, do not perform any service unless qualified to do so. Do not attempt internal service or adjustment unless another person, capable of rendering first aid and resuscitation, is present.
- Do not install substitute parts or perform any unauthorized modification to the instrument.
- Capacitors inside the instrument may retain a charge even if the instrument is disconnected from its source of supply.
- Do not operate the instrument in the presence of flammable gases or fumes. Operation of any electrical instrument in such an environment constitutes a definite safety hazard.
- Do not use the instrument in a manner not specified by the manufacturer.

To clean the instrument

If the instrument requires cleaning: (1) Remove power from the instrument. (2) Clean the external surfaces of the instrument with a soft cloth dampened with a mixture of mild detergent and water. (3) Make sure that the instrument is completely dry before reconnecting it to a power source.

Safety Symbols



Instruction manual symbol: the product is marked with this symbol when it is necessary for you to refer to the instruction manual in order to protect against damage to the product.



Hazardous voltage symbol.



Earth terminal symbol: Used to indicate a circuit common connected to grounded chassis.

Index

A

adapter, E5386A half-channel, 16

C

channels, 8, 9

characteristics

E5378A 100-pin single ended probe, 20

E5379A 100-pin differential probe, 20

E5380A 38-pin single ended probe, 30

E5386A half-channel adapter, 35

circuit board design, 55

cleaning the instrument, 71

clock inputs

E5378A 100-pin single-ended probe, 61

E5379A 100-pin differential probe, 62

E5380A 38-pin single-ended probe, 63

per operating mode, 59

connector part numbers, 69

D

data inputs, 59

E5378A 100-pin single-ended probe, 61

E5379A 100-pin differential probe, 62

design

high-speed digital, 68

MECL system, 68

theory, 55

differential input amplitude definition, 13

differential probe

E5379A 100-pin, 8, 13

dimensions

E5378A 100-pin single-ended probe, 20

E5379A 100-pin differential probe, 20

E5380A 38-pin single-ended probe, 30

E5386A half-channel adapter, 35

MICTOR connector, 31

MICTOR footprint, 32

MICTOR support shroud, 31

MICTOR support shroud mounting holes, 32

Samtec, 22

Samtec connector, 21

Samtec connector footprint, 23

Samtec support shroud mounting holes, 23

E

electrical considerations, 41

equivalent probe loads, 42

eye opening

E5378A 100-pin single-ended probe, 51

E5379A 100-pin differential probe, 51

eye scan, 51, 59

F

footprint dimensions

100-pin Samtec, 23

38-pin MICTOR, 32

H

half-channel adapter, 8, 9, 16, 35

half-channel mode, 65

I

input impedance, 44

instrument, cleaning the, 71

L

labels, 64

M

mechanical considerations, 19

MICTOR

compatible probe, 30

connector, 9, 32

connector dimensions, 31

support shroud dimensions, 31

N

number of probes required, 10

O

operating mode, 59

ordering parts, 70

P

pin assignment

E5378A 100-pin single-ended probe, 24

E5379A 100-pin differential probe, 27

E5386A used with E6378A, 36

E5386A used with E6379A, 37

probe

E5378A 100-pin single-ended, 12, 20

E5379A 100-pin differential, 13, 20

E5380A 100-pin single-ended, 14

number required, 10

state speed, 11

probe characteristics

E5378A 100-pin single-ended, 20

E5379A 100-pin differential, 20

E5380A 38-pin single ended, 30

Index

- probe dimensions
 - E5378A 100-pin single ended, [20](#)
 - E5379A 100-pin differential, [20](#)
 - E5380A 38-pin single-ended, [30](#)
 - probe eye opening
 - E5378A 100-pin single-ended, [51](#)
 - E5379A 100-pin differential, [51](#)
 - probe load
 - E5378A 100-pin single-ended probe, [42](#)
 - E5379A 100-pin differential probe, [42](#)
 - E5380A 38-pin single-ended probe, [43](#)
 - probe step inputs
 - E5378A 100-pin single-ended, [48](#)
 - E5379A 100-pin differential, [48](#)
 - probe TDT
 - E5378A 100-pin single-ended, [45](#)
 - E5379A 100-pin differential, [45](#)
 - probing options, [7](#)
- ## R
- recommended reading, [67](#)
 - reordered bits, [64](#)
 - replaceable parts, [69](#)
 - required number of probes, [10](#)
 - routing, [57](#)
- ## S
- Samtec connector, [8](#)
 - dimensions, [21](#)
 - footprint dimensions, [23](#)
 - signal access, [64](#)
 - single-ended probe
 - E5378A 100-pin, [8, 12](#)
 - E5380A 38-pin, [9, 14](#)
 - specifications, see characteristics, [20](#)
 - state speed, [8, 9, 11](#)
 - step inputs
 - E5378A 100-pin single-ended probe, [48](#)
 - E5379A 100-pin single-ended probe, [48](#)
 - support shroud, [22](#)
 - MICTOR dimensions, [31](#)
 - MICTOR mounting hold dimensions, [33](#)
 - replacement part numbers, [69](#)
 - Samtec dimensions, [22](#)
 - Samtec mounting hole dimensions, [23](#)
 - supported state speed, [11](#)
 - synchronous state analysis, [59](#)
- ## T
- theory, [55](#)
 - thresholds, [61](#)
 - time domain transmission
 - E5378A 100-pin single-ended probe, [45](#)
 - E5379A 100-pin differential probe, [45](#)
 - transmission line considerations, [56](#)