

# Model 2000 6½-Digit Multimeter

## Datasheet

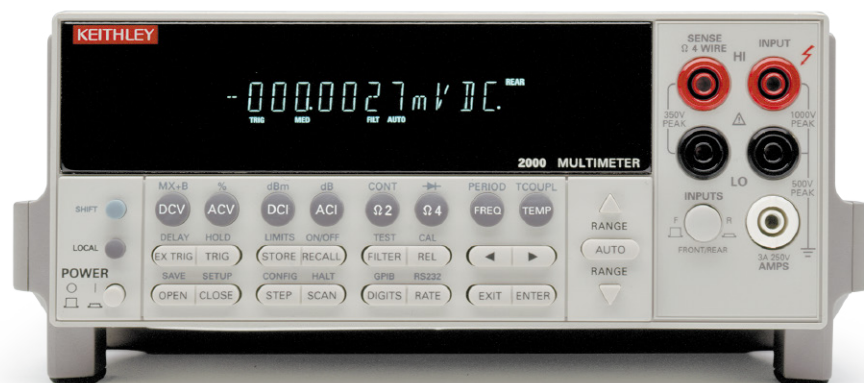

**KEITHLEY**  
A Tektronix Company

The Model 2000 6½-Digit Multimeter is part of Keithley's family of high performance DMMs. Based on the same high speed, low noise A/D converter technology as the Model 2001 and 2002, the 2000 is a fast, accurate, and highly stable instrument that's as easy to operate as it is to afford. It combines broad measurement ranges with superior accuracy specifications — DC voltage from 100nV to 1kV (with 0.002% 90-day basic accuracy) and DC resistance from 100μΩ to 100MΩ (with 0.008% 90-day basic accuracy). Optional switch cards enable multiplexing up to 20 different input signals for multipoint measurement applications.

### High Throughput

The 2000 offers exceptional measurement speed at any resolution. At 6½ digits, it delivers 50 triggered rdgs/s over the IEEE-488 bus. At 4½ digits, it can read up to 2000 rdgs/s into its internal 1024 reading buffer, making it an excellent choice for applications where throughput is critical.

For benchtop or stand-alone applications, the 2000 has a front panel design that's simple to understand and easy to use. The 2000 has 13 built-in measurement functions, including DCV, ACV, DCI, ACI, 2WΩ, 4WΩ, temperature, frequency, period, dB, dBm, continuity measurement, and diode testing. A built-in RS-232 interface connects to a notebook or full-sized PC's serial port to take, store, process, and display measurements automatically.

### Key Features

- 13 built-in measurement functions
- 2000 readings/second at 4½ digits
- Optional scanner cards for multipoint measurements
- GPIB and RS-232 interfaces
- Fluke 8840/42 command set

### Ordering Information

**2000**  
6½-Digit DMM

**2000/2000-SCAN**  
6½-Digit DMM/Scanner Combination

### Accessories Supplied

Instruction Manual and Model  
1751 Safety Test Leads

### Accessories Available

2000-SCAN	10-channel, General-Purpose Scanner Card
2001-SCAN	10-channel Scanner Card with two high-speed channels
2001-TCSCAN	9-channel, Thermocouple Scanner Card with built-in cold junction

#### CABLES/ADAPTERS

7007-1	Shielded IEEE-488 Cable, 1m (3.3 ft)
7007-2	Shielded IEEE-488 Cable, 2m (6.6 ft)
7009-5	RS-232 Cable

#### RACK MOUNT KITS

4288-1	Single Fixed Rack Mount Kit
4288-2	Dual Fixed Rack Mount Kit

#### GPIB INTERFACES

KPCI-488LPA	IEEE-488 Interface/Controller for the PCI Bus
KUSB-488B	IEEE-488 USB-to-GPIB Interface Adapter

### Services Available

**2000-SCAN-3Y-EW**  
1-year factory warranty extended to 3 years from date of shipment

**2000-3Y-EW**  
1-year factory warranty extended to 3 years from date of shipment

**2001-TCSCAN-3Y-EW**  
1-year factory warranty extended to 3 years from date of shipment

**C/2000-3Y-ISO**  
3 (ISO-17025 accredited) calibrations within 3 years of purchase for Models 2000, 2000-SCAN\*

**C/2001-3Y-ISO**  
3 (ISO-17025 accredited) calibrations within 3 years of purchase for Model 2001-TCSCAN\*

\*Not available in all countries

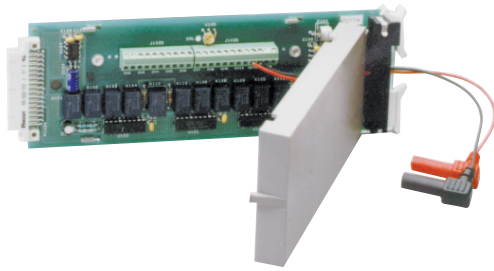

### Optional Multiplexer Cards

Creating a self-contained multipoint measurement solution is as simple as plugging a scanner card into the option slot on the 2000's back panel. This approach eliminates the complexities of triggering, timing, and processing issues and helps reduce test time significantly. For applications involving more than 10 measurement points, the 2000 is compatible with Keithley's switch matrices and cards.

#### Model 2000-SCAN Scanner Card

- Ten analog input channels (2-pole)
- Configurable as 4-pole, 5-channel

#### Model 2001-SCAN Scanner Card

- Ten analog input channels
- Two channels of 2-pole, high-speed, solid-state switching

#### Model 2001-TCSCAN Thermocouple Scanner Card

- Nine analog input channels
- Built-in temperature reference for thermocouple cold-junction compensation

### SCANNER OPTION 2000-SCAN

**GENERAL:** 10 channels of 2-pole relay input. All channels configurable to 4-pole.

**CAPABILITIES:** Multiplex one of ten 2-pole or one of five 4-pole signals into DMM.

#### INPUTS

##### Maximum Signal Level:

- DC Signals:** 110V DC, 1A switched, 30VA maximum (resistive load).
- AC Signals:** 125V AC rms or 175V AC peak, 100kHz maximum, 1A switched, 62.5VA maximum (resistive load).
- Contact Life:** >10<sup>5</sup> operations at maximum signal level; >10<sup>8</sup> operations cold switching.
- Contact Resistance:** <1Ω at end of contact life.
- Actuation Time:** 2.5ms maximum on/off.
- Contact Potential:** <±500nV typical per contact, 1μV max. <±500nV typical per contact pair, 1μV max.
- Connector Type:** Screw terminal, #22 AWG wire size.
- Isolation Between Any Two Terminals:** >10<sup>9</sup>Ω, <75pF.
- Isolation Between Any Terminal and Earth:** >10<sup>9</sup>Ω, <150pF.
- Common Mode Voltage:** 350V peak between any terminal and earth.
- Maximum Voltage Between Any Two Terminals:** 200V peak.
- Maximum Voltage Between Any Terminal and Model 2001 Input LO:** 200V peak.

**ENVIRONMENTAL:** Meets all Model 2000 environmental specifications.

**DIMENSIONS, WEIGHT:** 21mm high × 72mm wide × 221mm deep (0.83 in. × 2.83 in. × 8.7 in.). Adds 0.4kg (10 oz.).

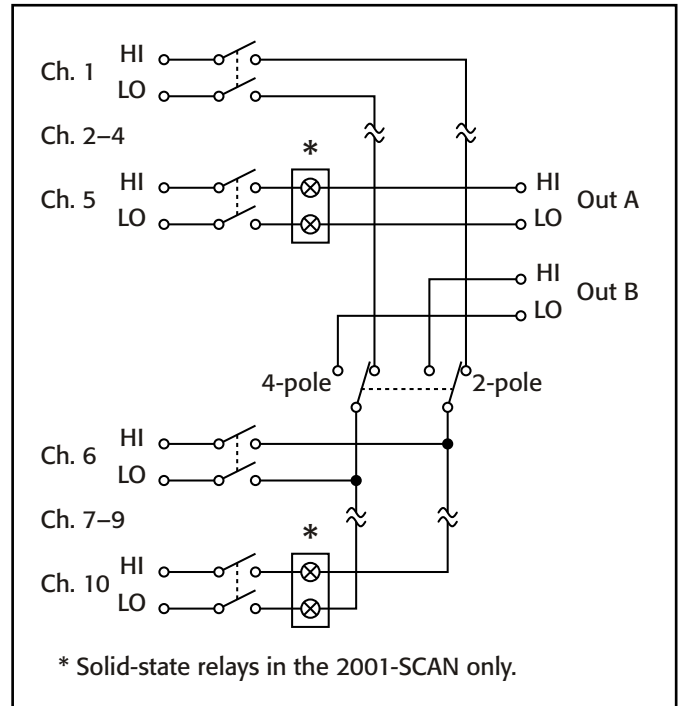

Scanner Configuration for Models 2000-SCAN and 2001-SCAN

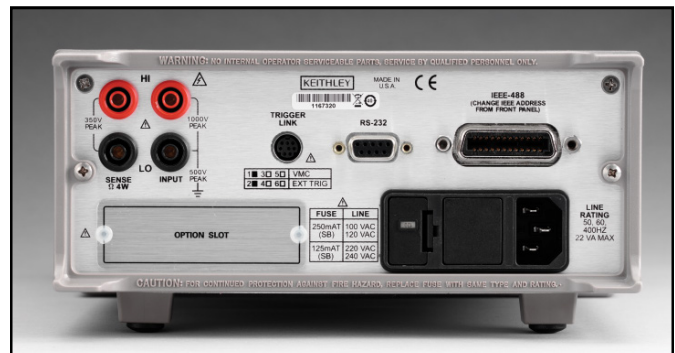

**DC Characteristics**

Conditions: MED (1 PLC)<sup>1</sup> or SLOW (10 PLC) or MED (1 PLC) with filter of 10

Accuracy: ±(ppm of reading + ppm of range)  
(ppm = parts per million)  
(e.g., 10ppm = 0.001%)

Function	Range	Resolution	Test Current or Burden Voltage (±5%)	Input Resistance	24 Hour <sup>14</sup> 23°C ± 1°	90 Day 23°C ± 5°	1 Year 23°C ± 5°	Temperature Coefficient 0°–18°C and 28°–50°C
<b>Voltage</b>	100.0000 mV	0.1 µV		> 10 GΩ	30 + 30	40 + 35	50 + 35	2 + 6
	1.000000 V	1.0 µV		> 10 GΩ	15 + 6	25 + 7	30 + 7	2 + 1
	10.00000 V	10 µV		> 10 GΩ	15 + 4	20 + 5	30 + 5	2 + 1
	100.0000 V	100 µV		10 MΩ ±1%	15 + 6	30 + 6	45 + 6	5 + 1
	1000.000 V <sup>9</sup>	1 mV		10 MΩ ±1%	20 + 6	35 + 6	45 + 6	5 + 1
<b>Resistance<sup>15</sup></b>	100.0000 Ω	100 µΩ	1 mA		30 + 30	80 + 40	100 + 40	8 + 6
	1.000000 kΩ	1 mΩ	1 mA		20 + 6	80 + 10	100 + 10	8 + 1
	10.00000 kΩ	10 mΩ	100 µA		20 + 6	80 + 10	100 + 10	8 + 1
	100.0000 kΩ	100 mΩ	7 µA		20 + 6	80 + 10	100 + 10	8 + 1
	1.000000 MΩ <sup>16</sup>	1 Ω	7 µA		20 + 6	80 + 10	100 + 10	8 + 1
	10.00000 MΩ <sup>11, 16</sup>	10 Ω	700 nA // 10MΩ		150 + 6	200 + 10	400 + 10	95 + 1
	100.0000 MΩ <sup>11, 16</sup>	100 Ω	700 nA // 10MΩ		800 + 30	1500 + 30	1500 + 30	900 + 1
<b>Current</b>	10.00000 mA	10 nA	< 0.15 V		60 + 30	300 + 80	500 + 80	50 + 5
	100.0000 mA	100 nA	< 0.03 V		100 + 300	300 + 800	500 + 800	50 + 50
	1.000000 A	1 µA	< 0.3 V		200 + 30	500 + 80	800 + 80	50 + 5
	3.000000 A	10 µA	< 1 V		1000 + 15	1200 + 40	1200 + 40	50 + 5
<b>Continuity 2W</b>	1 kΩ	100 mΩ	1 mA		40 + 100	100 + 100	120 + 100	8 + 1
<b>Diode Test</b>	3.00000 V	10 µV	1 mA		20 + 6	30 + 7	40 + 7	8 + 1
	10.00000 V	10 µV	70 µA		20 + 6	30 + 7	40 + 7	8 + 1
	10.00000 V	10 µV	7 µA		20 + 6	30 + 7	40 + 7	8 + 1

**DC OPERATING CHARACTERISTICS<sup>2</sup>**

Function	Digits	Readings/s	PLCs <sup>8</sup>
DCV (all ranges),	6½ <sup>3,4</sup>	5	10
DCI (all ranges), and	6½ <sup>3,7</sup>	30	1
Ohms (<10M range)	6½ <sup>3,5</sup>	50	1
	5½ <sup>3,5</sup>	270	0.1
	5½ <sup>5</sup>	500	0.1
	5½ <sup>5</sup>	1000	0.04
	4½ <sup>5</sup>	2000	0.01

**DC SYSTEM SPEEDS<sup>2,6</sup>**

**RANGE CHANGE<sup>3</sup>:** 50/s.

**FUNCTION CHANGE<sup>3</sup>:** 45/s.

**AUTORANGE TIME<sup>3,10</sup>:** <30ms.

**ASCII READINGS TO RS-232 (19.2K BAUD):** 55/s.

**MAX. INTERNAL TRIGGER RATE:** 2000/s.

**MAX. EXTERNAL TRIGGER RATE:** 400/s.

**DC GENERAL**

**LINEARITY OF 10VDC RANGE:** ±(1ppm of reading + 2ppm of range).

**DCV, Ω, TEMPERATURE, CONTINUITY, DIODE TEST INPUT PROTECTION:** 1000V, all ranges.

**MAXIMUM 4WΩ LEAD RESISTANCE:** 10% of range per lead for 100Ω and 1kΩ ranges; 1kΩ per lead for all other ranges.

**DC CURRENT INPUT PROTECTION:** 3A, 250V fuse.

**SHUNT RESISTOR:** 0.1Ω for 3A, 1A, and 100mA ranges. 10Ω for 10mA range.

**CONTINUITY THRESHOLD:** Adjustable 1Ω to 1000Ω.

**AUTOZERO OFF ERROR:** Add ±(2ppm of range error + 5µV) for <10 minutes and ±1°C change.

**OVERRANGE:** 120% of range except on 1000V, 3A, and diode.

**SPEED AND NOISE REJECTION**

Rate	Readings/s	Digits	RMS Noise 10V		
			Range	NMRR <sup>12</sup>	CMRR <sup>13</sup>
10 PLC	5	6½	< 1.5 µV	60 dB	140 dB
1 PLC	50	6½	< 4 µV	60 dB	140 dB
0.1 PLC	500	5½	< 22 µV	—	80 dB
0.01 PLC	2000	4½	< 150 µV	—	80 dB

**DC NOTES**

- Add the following to "ppm of range" uncertainty: 1V and 100V, 2ppm; 100mV, 15ppm; 100Ω, 15ppm; 1kΩ–<1MΩ, 2ppm; 10mA and 1A, 10ppm; 100mA, 40ppm.
- Speeds are for 60Hz operation using factory default operating conditions (\*RST). Autorange off, Display off, Trigger delay = 0.
- Speeds include measurement and binary data transfer out the GPIB.
- Auto zero off.
- Sample count = 1024, auto zero off.
- Auto zero off, NPLC = 0.01.
- Ohms = 24 readings/second.
- 1 PLC = 16.67ms @ 60Hz, 20ms @ 50Hz/400Hz. The frequency is automatically determined at power up.
- For signal levels >500V, add 0.02ppm/V uncertainty for the portion exceeding 500V.
- Add 120ms for ohms.
- Must have 10% matching of lead resistance in Input HI and LO.
- For line frequency ±0.1%.
- For 1kΩ unbalance in LO lead.
- Relative to calibration accuracy.
- Specifications are for 4-wire ohms. For 2-wire ohms, add 1Ω additional uncertainty.
- For rear inputs, add the following to temperature coefficient "ppm of reading" uncertainty 10MΩ 95ppm, 100MΩ 900ppm. Operating environment specified for 0° to 50°C and 50% RH at 35°C.

### True RMS AC Voltage and Current Characteristics

			Accuracy <sup>1</sup> : ±(% of reading + % of range), 23°C ±5 °C				
Voltage Range	Resolution	Calibration Cycle	3 Hz–10 Hz <sup>10</sup>	10 Hz–20 kHz	20 kHz–50 kHz	50 kHz–100 kHz	100 kHz–300 kHz
100.0000 mV	0.1 µV						
1.000000 V	1.0 µV	90 Days	0.35 + 0.03	0.05 + 0.03	0.11 + 0.05	0.60 + 0.08	4 + 0.5
10.00000 V	10 µV						
100.0000 V	100 µV	1 Year	0.35 + 0.03	0.06 + 0.03	0.12 + 0.05	0.60 + 0.08	4 + 0.5
750.000 V	1 mV						
<b>Temperature Coefficient/°C<sup>8</sup></b>			0.035 + 0.003	0.005 + 0.003	0.006 + 0.005	0.01 + 0.006	0.03 + 0.01

Current Range	Resolution	Calibration Cycle	3 Hz–10 Hz	10 Hz–3 kHz	3 kHz–5 kHz
1.000000 A	1 µA	90 Day/1 Year	0.30 + 0.04	0.10 + 0.04	0.14 + 0.04
3.00000 A <sup>9</sup>	10 µA	90 Day/1 Year	0.35 + 0.06	0.15 + 0.06	0.18 + 0.06
<b>Temperature Coefficient/°C<sup>8</sup></b>			0.035 + 0.006	0.015 + 0.006	0.015 + 0.006

#### HIGH CREST FACTOR ADDITIONAL ERROR ±(% of reading)<sup>7</sup>

<b>CREST FACTOR:</b>	1–2	2–3	3–4	4–5
<b>ADDITIONAL ERROR:</b>	0.05	0.15	0.30	0.40

#### AC OPERATING CHARACTERISTICS<sup>2</sup>

Function	Digits	Readings/s	Rate	Bandwidth
ACV (all ranges), and	6½ <sup>3</sup>	2s/reading	SLOW	3 Hz–300 kHz
ACI (all ranges)	6½ <sup>3</sup>	1.4	MED	30 Hz–300 kHz
	6½ <sup>4</sup>	4.8	MED	30 Hz–300 kHz
	6½ <sup>3</sup>	2.2	FAST	300 Hz–300 kHz
	6½ <sup>4</sup>	35	FAST	300 Hz–300 kHz

#### ADDITIONAL LOW FREQUENCY ERRORS ±(% of reading)

	Slow	Med	Fast
20 Hz – 30 Hz	0	0.3	—
30 Hz – 50 Hz	0	0	—
50 Hz – 100 Hz	0	0	1.0
100 Hz – 200 Hz	0	0	0.18
200 Hz – 300 Hz	0	0	0.10
> 300 Hz	0	0	0

#### AC SYSTEM SPEEDS<sup>2, 5</sup>

**FUNCTION/RANGE CHANGE<sup>6</sup>:** 4/s.

**AUTORANGE TIME:** <3s.

**ASCII READINGS TO RS-232 (19.2K BAUD)<sup>4</sup>:** 50/s.

**MAX. INTERNAL TRIGGER RATE<sup>4</sup>:** 300/s.

**MAX. EXTERNAL TRIGGER RATE<sup>4</sup>:** 300/s.

#### AC GENERAL

**INPUT IMPEDANCE:** 1MΩ ±2% paralleled by <100pF.

**ACV INPUT PROTECTION:** 1000Vp.

**MAXIMUM DCV:** 400V on any ACV range.

**ACI INPUT PROTECTION:** 3A, 250V fuse.

**BURDEN VOLTAGE: 1A Range:** <0.3V rms. **3A Range:** <1V rms.

**SHUNT RESISTOR:** 0.1Ω on all ACI ranges.

**AC CMRR:** >70dB with 1kΩ in LO lead.

**MAXIMUM CREST FACTOR:** 5 at full scale.

**VOLT HERTZ PRODUCT:** ≈8 × 10<sup>7</sup> V·Hz.

**OVERRANGE:** 120% of range except on 750V and 3A ranges.

#### AC NOTES

- Specifications are for SLOW rate and sinewave inputs >5% of range.
- Speeds are for 60Hz operation using factory default operating conditions (\*RST). Auto zero off, Auto range off, Display off, includes measurement and binary data transfer out the GPIB.
- 0.01% of step settling error. Trigger delay = 400ms.
- Trigger delay = 0.
- DETECTOR: BANDwidth 300, NPLC = 0.01.
- Maximum useful limit with trigger delay = 175ms.
- Applies to non-sinewaves >5Hz and <500Hz (guaranteed by design for crest factors >4.3).
- Applies to 0°–18°C and 28°–50°C.
- For signal levels >2.2A, add additional 0.4% to "of reading" uncertainty.
- Typical uncertainties. Typical represents two sigma or 95% of manufactured units measure <0.35% of reading and three sigma or 99.7% measure <1.06% of reading.

## Triggering and Memory

**READING HOLD SENSITIVITY:** 0.01%, 0.1%, 1%, or 10% of reading.  
**TRIGGER DELAY:** 0 to 99 hrs (1ms step size).  
**EXTERNAL TRIGGER LATENCY:** 200µs + <300µs jitter with autozero off, trigger delay = 0.  
**MEMORY:** 1024 readings.

## Math Functions

Rel, Min/Max/Average/StdDev (of stored reading), dB, dBm, Limit Test, %, and mX+b with user defined units displayed.  
**DBM REFERENCE RESISTANCES:** 1 to 9999Ω in 1Ω increments.

## Standard Programming Languages

SCPI (Standard Commands for Programmable Instruments)  
 Keithley 196/199  
 Fluke 8840A, Fluke 8842A

## Remote Interface

GPIO (IEEE-488.1, IEEE-488.2) and RS-232C.

## Frequency and Period Characteristics <sup>1, 2</sup>

ACV Range	Frequency Range	Period Range	Gate Time	Resolution ±(ppm of reading)	Accuracy 90 Day/1 Year ±(% of reading)
100 mV to 750 V	3 Hz to 500 kHz	333 ms to 2 µs	1 s (SLOW)	0.3	0.01

### FREQUENCY NOTES

- Specifications are for square wave inputs only. Input signal must be >10% of ACV range. If input is <20mV on the 100mV range, then frequency must be >10Hz.
- 20% overrange on all ranges except 750V range.

## Temperature Characteristics

Thermocouple <sup>2, 3, 4</sup>

Type	Range	Resolution	Accuracy <sup>1</sup> 90 Day/1 Year (23°C ± 5°C)		
			Relative to Reference Junction	Using 2001-TCSCAN <sup>5</sup>	
J	-200 to + 760°C	0.001°C	±0.5°C	±0.65°C	
K	-200 to + 1372°C	0.001°C	±0.5°C	±0.70°C	
T	-200 to + 400°C	0.001°C	±0.5°C	±0.68°C	

### TEMPERATURE NOTES

- For temperatures <-100°C, add ±0.1°C and >900°C add ±0.3°C.
- Temperature can be displayed in °C, K or °F.
- Accuracy based on ITS-90
- Exclusive of thermocouple error.
- Specifications apply to channels 2-6. Add 0.06°C/channel from channel 6.

## General Information

**POWER SUPPLY:** 100V / 120V / 220V / 240V.  
**LINE FREQUENCY:** 50Hz to 60Hz and 400Hz, automatically sensed at power-up.  
**POWER CONSUMPTION:** 22VA.  
**VOLT HERTZ PRODUCT:** ≤8 × 10<sup>7</sup>V·Hz.  
**OPERATING ENVIRONMENT:** Specified for 0°C to 50°C. Specified to 80% R.H. at 35°C and at an altitude of up to 2000m.  
**STORAGE ENVIRONMENT:** -40°C to 70°C.  
**SAFETY:** Conforms to European Union Low Voltage Directive.  
**EMC:** Conforms to European Union EMC Directive.  
**WARMUP:** 1 hour to rated accuracy.  
**VIBRATION:** MIL-PRF-2800F Class 3 Random.  
**DIMENSIONS:**  
**Rack Mounting:** 89mm high × 213mm wide × 370mm deep (3.5 in × 8.38 in × 14.56 in).  
**Bench Configuration (with handle and feet):** 104mm high × 238mm wide × 370mm deep (4.13 in × 9.38 in × 14.56 in).  
**NET WEIGHT:** 2.9kg (6.3 lbs).  
**SHIPPING WEIGHT:** 5kg (11 lbs).

# Contact Continental Resources

## TEST EQUIPMENT RENTALS & SALES

- [TestEquipmentTeam@conres.com](mailto:TestEquipmentTeam@conres.com)
- [www.ConResTestEquipment.com](http://www.ConResTestEquipment.com)
- **1-800-937-4688**



**KEITHLEY**  
A Tektronix Company

